



**AXO<sup>®</sup> 08**  
LIGHT



AXO<sup>®</sup> LIGHT 08



# LIGHTING ICONS

---



# INDEX

---

216	ALEA
184	ARI
92	AURA
138	BALIOS
120	BALL UP
18	BLUM
190	BORA
194	CLARA
62	CLAVIUS
218	CRYSTAL SPOTLIGHT
180	ENTASIS
152	EXTREME
106	FALL IN LOVE
06	GLITTER
168	JAZZ
86	KALEIDOLIGHT
164	KORE
44	KOSHI
188	KROM
144	LEDGE
156	LOLLO
170	MARYLIN
56	MUSE
110	NELLY
208	PRIMULA
198	SHIRAZ
128	SLIGHT
24	SUBZERO
220	DESIGNERS
225	TECHNICAL DATA

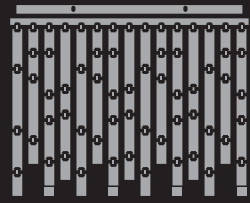

GLITTER

---

# GLITTER

---

DESIGN CANDIDO E MAMMINI

Collezione di lampade con catene di elementi in vetro specchiato, con montatura in acciaio lucido.

Lamp collection with chains of mirrored glass elements. Polished steel frame.

Leuchtenkollektion bestückt mit Glasspiegel-Kettenbehang. Struktur aus glänzendem Stahl.

Collection de lampes avec chaines au verre-miroir. Structure acier chromé.

Colección de lámparas con cadenas constituidas por elementos en vidrio espejado. Montadura en acero lúcido.



Коллекция светильников состоящих из серии пластинок из зеркального стекла. Оправа из глянцевой стали.



PL GLIT 16 - 1 x max 100 w - IAA/C - 1 x E27 / 1 x max 20 w - FBA - 1 x E27





**SP GLI 60 C** (pg 10) - 2 x max 100 w - IAA/C  - 2 x E27 / 2 x max 20 w - FBA  - 2 x E27 / **PL GLI 48 3** (pg 11) - 5 x max 100 w - IAA/C  - 5 x E27 / 5 x max 20 w - FBA  - 5 x E27



## GLITTER

**PL GL 32 L I**  
4 x max 50 w  
HMGS/UB   
4 x G53



AP GLITT C (pg 14) ~ 3 x max 60 w ~ IBP/C ● ~ 3 x E14 / SP GLITT 96 (pg 15) ~ 4 x max 100 w ~ IAA/C ● ~ 4 x E27 / 4 x max 20 w ~ FBA ● ~ 4 x E27





## GLITTER

### PL GLI 48 3 >

5 x max 100 w

IAA/C 

5 x E27

5 x max 20 w

FBA 

5 x E27





### SP GLITT G

13 x max 100 w

+ 4 x max 25 w

IAA/C + IBP/C

 + 

13 x E27 + 4 x E14



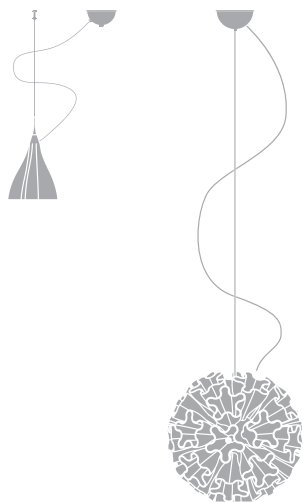

# BLUM

DESIGN MARCELLO FURLAN

Collezione in vetro soffiato con parti in metallo cromato. Disponibile nelle versioni con vetro trasparente e cromato.

Blown glass lamp collection with chrome-plated parts. Available in transparent or chrome-plated glass versions.

Kollektion aus handgefertigtem Glas mit verchromten Metallteilen. Folgende Glasvariationen sind erhältlich: transparent und verchromtes Glas.

Collection de lampes en verre soufflé avec des parts métal en chrome. Disponible avec verre en transparente et chromé.

Colección de vidrio soplado con partes de metal cromo. Disponible en las versiones de vidrio transparente y cromo.

Коллекция из дутого стекла и хромированного металла. Предлагаются в вариантах с прозрачным и хромированным стеклом.

SP BLUM 31 ~ 31 x max 60 w ~ IBP/C ~ 31 x E14



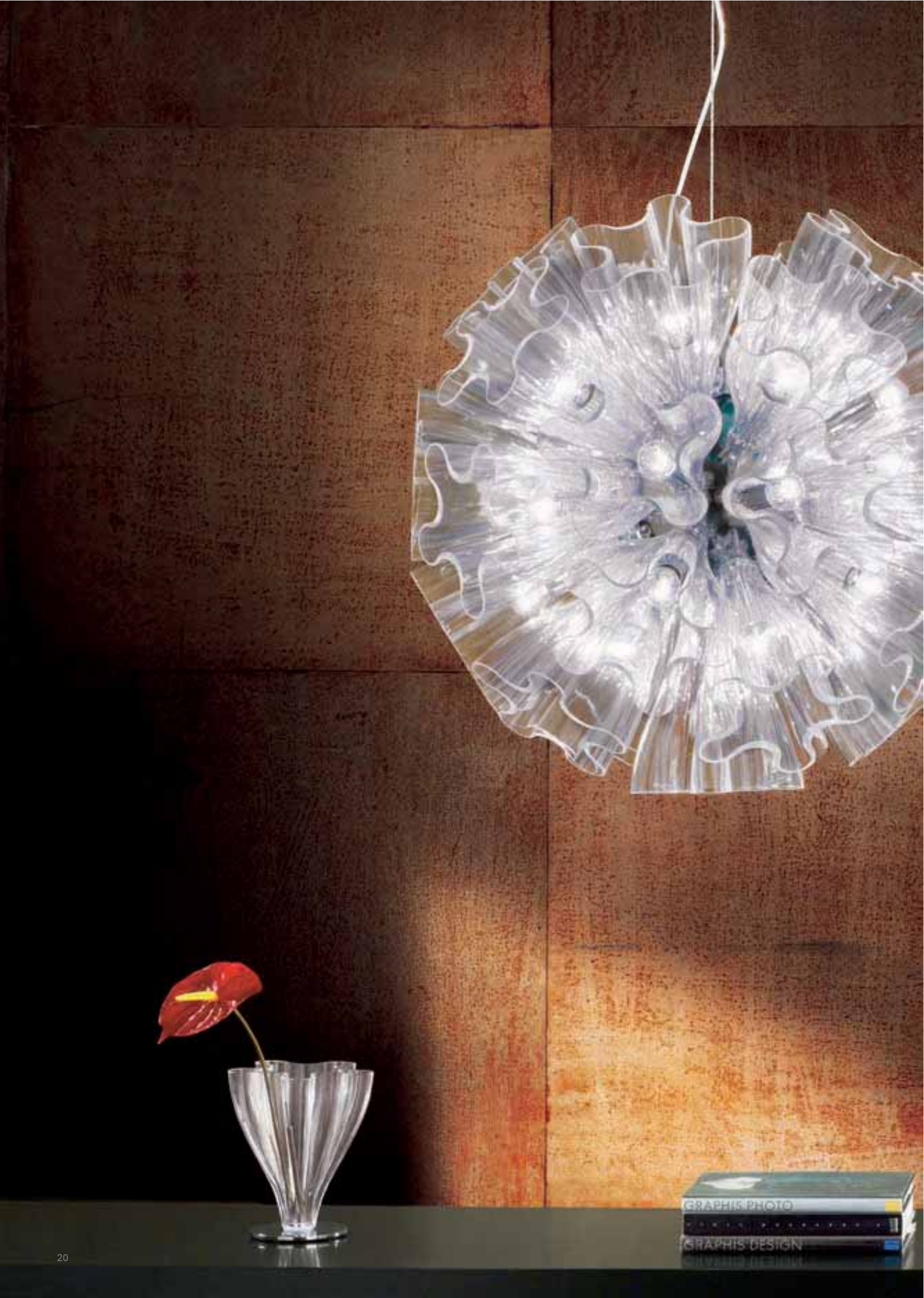







# BLUM

**SP BLUM 1**  
1 x max 60 w  
IBP/C   
1 x E14



◀ **SP BLUM 19**  
19 x max 60 w  
IBP/C   
19 x E14

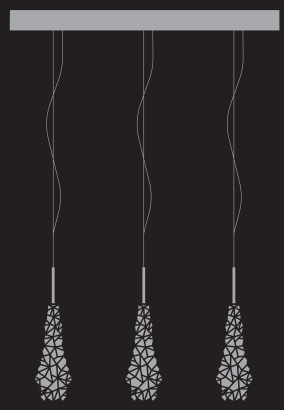
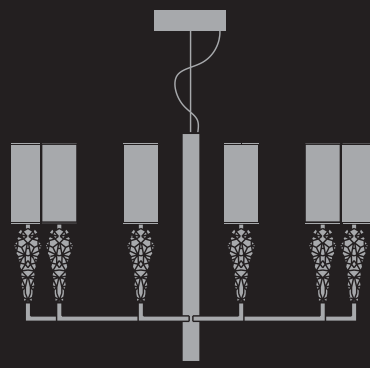

SUBZERO

---

# SUBZERO

## DESIGN MANUEL VIVIAN

---

Collezione completa di lampade in cristallo di Bohemia e montatura con finitura in metallo cromato. I paralumi montati su alcuni articoli sono disponibili nei colori: cromo interno alluminio gofrato, rosso interno bianco, vaniglia interno oro, bianco interno bianco. Le plafoniere sono dotate di lastra di copertura in vetro nero bisellato.

Bohemian crystal lamp collection with chrome-plated structure. The lampshades mounted on some items are available in the following colours: chrome exterior with embossed aluminium interior, red exterior with white interior, vanilla exterior with gold interior, white exterior with white interior. Ceiling lamps are equipped with a black beveled glass covering plate.



Komplette Leuchtenkollektion aus böhmischem Bleikristall und verchromter Struktur. Die Lampenschirme einiger bestimmter Artikel sind in folgenden Farben erhältlich: chrom und interner Aluminium-Prägedruk, rot und innen weiß, vanillefarben und innen goldfarben, weiß und innen weiß. Die Deckenleuchten bestehen aus einer mit an den Enden abgeschrägten, schwarzen Glasplatte.

Collection de lampes complets en cristal du Bohemia et structure avec finition en métal chromé. Les abat-jours de quelques articles ont disponible en couleurs : chrom et aluminium travaillé en relief dedans, rouge et blanc dedans, vanille et or dedans, blanc et blanc dedans. Les plafonniers sont copris avec du verre noir et polis.

Colección completa de lámparas en cristal de Bohemia y montadura con acabado en metal cromado. Las pantallas montadas en unos artículos son disponibles en los colores: cromo (interno en aluminio imprimido en relieve), rojo (interno blanco), vanilla (interno oro) y blanco (interno blanco). Los plafones son dotados de una plancha de cobertura en vidrio amolado negro.

Коллекция ламп из богемского хрусталя с оправой из хромированного металла. Абажур предлагается в следующей цветовой гамме: хромированный снаружи и гофрированный алюминий внутри, красный снаружи и белый внутри, цвет ванили снаружи и золотой внутри, белый снаружи и внутри. Плафоны обеспечены декоративной плитой из чёрного стекла.



LT SUBZER - 1 x max 40 w - IBB/W  - 1 x E14 / 1 x max 9 w - FBB  - 1 x E14







## SUBZERO

### 3x SP SUBZ DE

3 x max 20 w

HSGST/UB 

3 x G4



### ◀ SP SUBZE 6

6 x max 20 w

HSGST/UB 

6 x G4

### ◀ LT SUBZER

1 x max 40 w

IBB/W 

1 x E14

1 x max 9 w

FBB 

1 x E14

# SUBZERO



## LT SUBZER

1 x max 40 w

IBB/W 

1 x E14

1 x max 9 w

FBB 

1 x E14





## SUBZERO

**SP SUBZ 10**  
10 x max 40 w  
+ 1 x max 50 w  
IBB/W + HRGS/UB  
🔦 + 🔊 alu  
10 x E14 + 1 x GU10



# SUBZERO

## SP SUBZ 50

50 x max 40 w

+ 1 x max 50 w

IBB/W + HRGS/UB

☉ + ☼ alu

50 x E14 + 1 x GU10









SP SUBZ 20 - 20 x max 40 w + 1 x max 50 w - IBB/W + HRGS/UB  +  alu - 20 x E14 + 1 x GU10

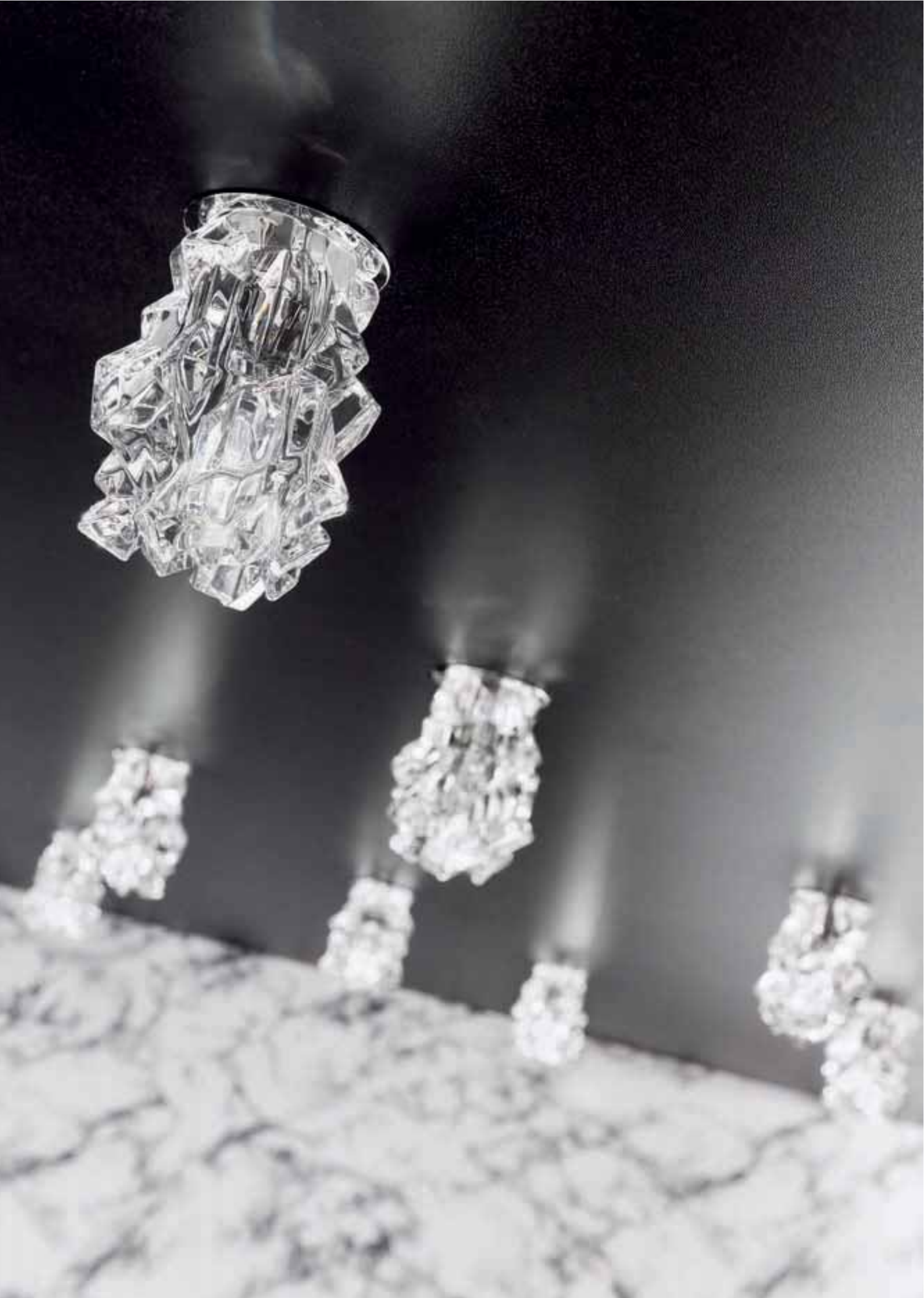

## SUBZERO



### FA SUBZ 15

1 x max 20 w

HSGST/UB 

1 x G4

### < FA SUBZER

1 x max 20 w

HSGST/UB 

1 x G4

## SUBZERO

**PL SUBZ 16** >  
16 x max 20 w  
HSGST/UB   
16 x G4



**PL SUBZE 5**  
5 x max 20 w  
HSGST/UB   
5 x G4

**AP SUBZER** >  
1 x max 40 w  
IBB/W   
1 x E14

1 x max 9 w  
FBB   
1 x E14



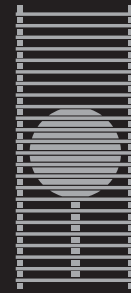
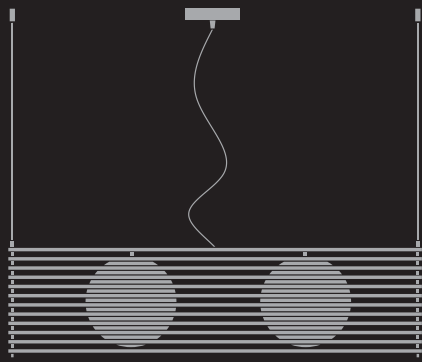



# KOSHI

---

## DESIGN MANUEL VIVIAN

Collezione di lampade con paralume in legno di bambu' finitura wengé e diffusori in vetro soffiato bianco satinato. Finiture cromate.

Lamp collection with wengé finished bamboo lampshades and white satin-finished blown glass diffusers. Chrome-plated fittings.

Leuchtenkollektion mit Lampenschirm aus Bambusholz, Ausführung Wengè, Diffusoren aus mundgeblasenem Glas, weiß satiniert. Metallteile verchromt.

Collection de lampes avec abat-jour en bois de bambou finitions wengé et diffuseurs en verrerie soufflée blanc satiné. Finitions chromées.

Colección de lámparas con pantalla de madera de bambú acabado wengue y difusor de vidrio bufado blanco satinado. Acabados cromados.

Коллекция ламп с абажуром из бамбука, обработанного методом венге и с белым сатинированным центральным ядром из дутого стекла. Оправа охранирована.



SP KOSHIM - 1 x max 100 w - HSGST/CUB  - 1 x E27





LT KOSHI G (pg 48) → 1 x max 100 w → HSGST/C/UB  → 1 x E27 / SP KOSHI G (pg 49) → 2 x max 100 w → HSGST/C/UB  → 2 x E27



# KOSHI

**SP KOSHI G**  
2 x max 100 w  
HSGST/C/UB   
2 x E27



**SP KOSHI P**  
1 x max 40 w  
HSGST/C/UB   
1 x G9

**LT KOSHI P**  
1 x max 40 w  
HSGST/C/UB   
1 x G9

# KOSHI

**PL KOSHI** >  
1 x max 150 w  
HDG (118)   
1 x R7s



**AP KOSHI**  
1 x max 100 w  
HDG (78)   
1 x R7s





## KOSHI



### PT KOSHI

1 x max 150 w

HSGST/C/UB 

1 x E27

### < LT KOSHI P

1 x max 40 w

HSGST/C/UB 

1 x G9



# MUSE

DESIGN SANDRO SANTANTONIO

Collezione di lampade da soffitto, da parete e sospensione, con struttura metallica e rivestimento in tessuto setato bianco elasticizzato, sfoderabile e lavabile.

Collection of suspension, wall and ceiling lamps with metal structure. The covering is made of a removable and washable white silken elastic fabric.

Kollektion bestehend aus Decken, Wänden- und Pendelleuchten, Struktur aus Metall und weiß-seidigem Überzug aus elastischem abnehmbaren Stoff. Waschbar.

Collection de plafonniers, appliques et suspension avec structure en métal. Etoffé par tissu soie-blanc élastique, déhoussable et lavable.

Colección de plafones, lámparas de pared y colgantes con estructura en metal y revestimiento en tejido blanco perlado elástico, desenfundable y lavable.

Коллекция подвесных, настенных и потолочных ламп, которые состоят из металлической структуры, обтянутой эластичной белой тканью с жемчужным отливом.

PL MUSE 80 - 3 x max 100 w - IAA/W  - 3 x E27 / 1 x max 55 w - FSC  - 1 x 2GX13







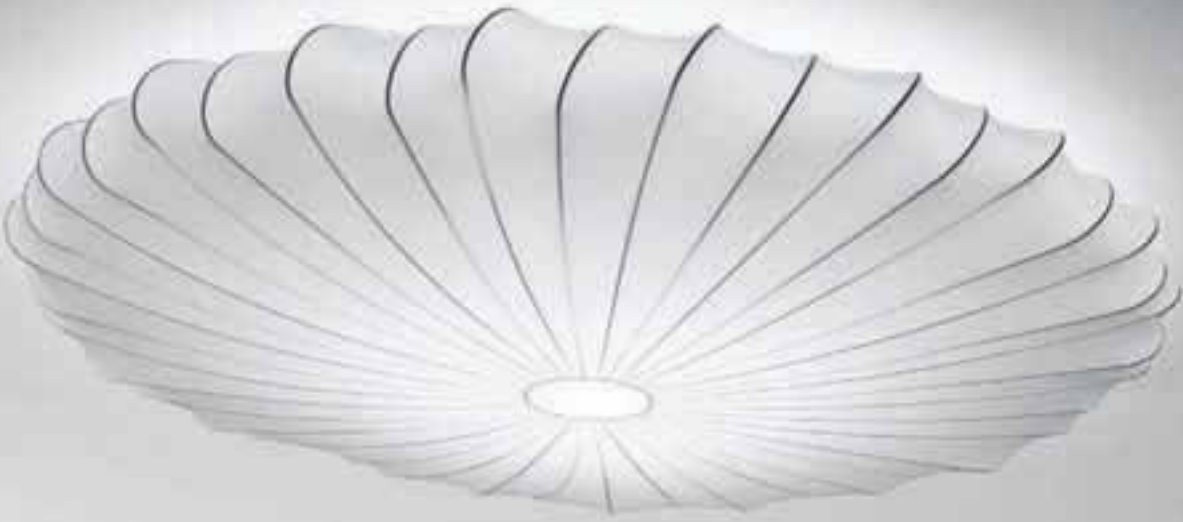

# MUSE

## ◀ PL MUS 120

3 x max 100 w

IAA/W 

3 x E27

1 x max 55 w

FSC 

1 x 2GX13

## SP MUSE

1 x max 150 w

IAG/WP 

1 x E27 globe

1 x max 21 w

FBT 

1 x E27



## ◀ PL MUSE 80

3 x max 100 w

IAA/W 

3 x E27

1 x max 55 w

FSC 

1 x 2GX13

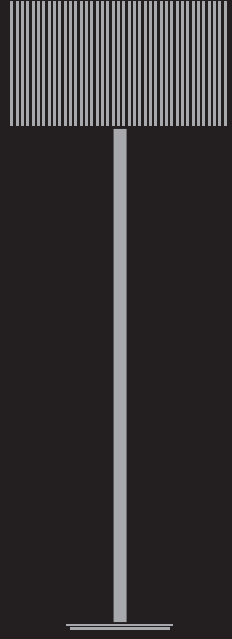
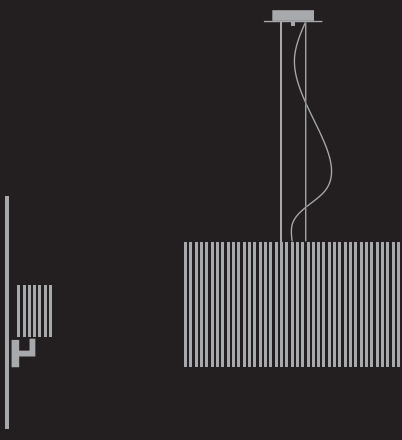

CLAVIUS

---

# CLAVIUS

---

## DESIGN MANUEL VIVIAN

Collezione di lampade con montatura cromata e paralume lavorato a mano con fili di seta. Disponibile in tre colori: bianco avorio, tabacco e nero. Diffusore in metacrilato opalino.

Lamp collection with chrome-plated frame and handmade silken thread lampshades. Available in three colours: ivory white, tobacco or black. Opal methacrylate diffuser.

Leuchtenkollektion mit verchromter Struktur - handgefertigter Lampenschirm aus Seidenfäden in elfenbein, tabakfarben oder schwarz. Opaler Methacrylreflektor.

Collection de lampes avec structure chromée et abat-jour en fil de soie fabriqué à la main. Disponible en trois couleurs: "blanc d'ivoire", "tabac" et noir. Diffuseur en méthacrylate opalin.

Colección de lámparas con engarces cromados y pantalla hecha a mano con hilos de seda. Disponible en tres colores: blanco avorio, tabaco y negro. Difusor de metacrilato opalino.

Коллекция светильников с хромированной структурой и абажуром, выполненным ручной работы из тонких нитей, создавая шёлковый эффект. Цвета в наличии: белый слоновой кости, табачный, чёрный. Рассеиватель из матового метакрилата.



SP CLAVIU - 3 x max 100 w - IAA/F  - 3 x E27 / 1 x max 39 w - FDH  - 1 x G5 / PT CLAVIU - 2 x max 100 w - IAA/F  - 2 x E27

SP CLAV 40 - 4 x max 60 w - IAA/F  - 4 x E27







## CLAVIUS

**SP CL 60 40**  
4 x max 100 w  
IAA/F   
4 x E27



◀ **SP CLAVI P**  
2 x max 100 w  
IAA/F   
2 x E27

# CLAVIUS



## SP CLAV 40

4 x max 60 w

IAA/F 

4 x E27

## SP CLAV 60 >

4 x max 100 w

IAA/F 

4 x E27





## PT CLAV 60 >

4 x max 100 w

IAA/F 

4 x E27



AP CLAV 30 [pg 72] - 1 x max 60 w - IBB/W  - 1 x E14 / 1 x max 18 w - FSQ  - 1 x G24d-2 / SP CLAVIU [pg 73] - 3 x max 100 w - IAA/F  - 3 x E27 / 1 x max 39 w - FDH  - 1 x G5









# CLAVIUS

## FA CLAVIU

1 x max 35 w  
HAGS/UB   
1 x GU 5.3

## ◀ AP CLAV BR

1 x max 60 w  
IBB/W   
1 x E14

## ◀ LT CLAVI P

2 x max 60 w  
IBB/W   
2 x E14



# CLAVIUS



## AP CLAV 45

2 x max 40 w



IBB/W 

2 x E14

2 x max 40 w

+ 1 x max 25 w

HAGS/UB + HSGST/C/UB

 + 

2 x E14 halopar 16ALU

+ 1 x G9

2 x max 18 w

FSMH 

2 x GX24q-2

## LT CLAV XP >

1 x max 60 w

IBB/W 

1 x E14





# CLAVIUS

## ◀ PL CLAVIU

3 x max 60 w

IAA/F 

3 x E27

1 x max 55 w

FSC 

1 x 2GX13

## ◀ AP CLAV PI

2 x max 60 w

IBB/W 

2 x E14

1 x max 36 w

FSD 

1 x 2G11

## AP CLAV PI

2 x max 60 w

IBB/W 

2 x E14

1 x max 36 w

FSD 

1 x 2G11









# CLAVIUS



**LT CLAVI P**  
2 x max 60 w  
IBB/W   
2 x E14

**LT CLAVI G**  
2 x max 100 w  
IAA/F   
2 x E27



**LT CLAV XP**   
1 x max 60 w  
IBB/W   
1 x E14



LT CLAVI G (pg 84 – 85) – 2 x max 100 w – IAA/F  – 2 x E27 / LT CLAVI P (pg 85) – 2 x max 60 w – IBB/W  – 2 x E14 / LT CLAV XP (pg 85) – 1 x max 60 w – IBB/W  – 1 x E14

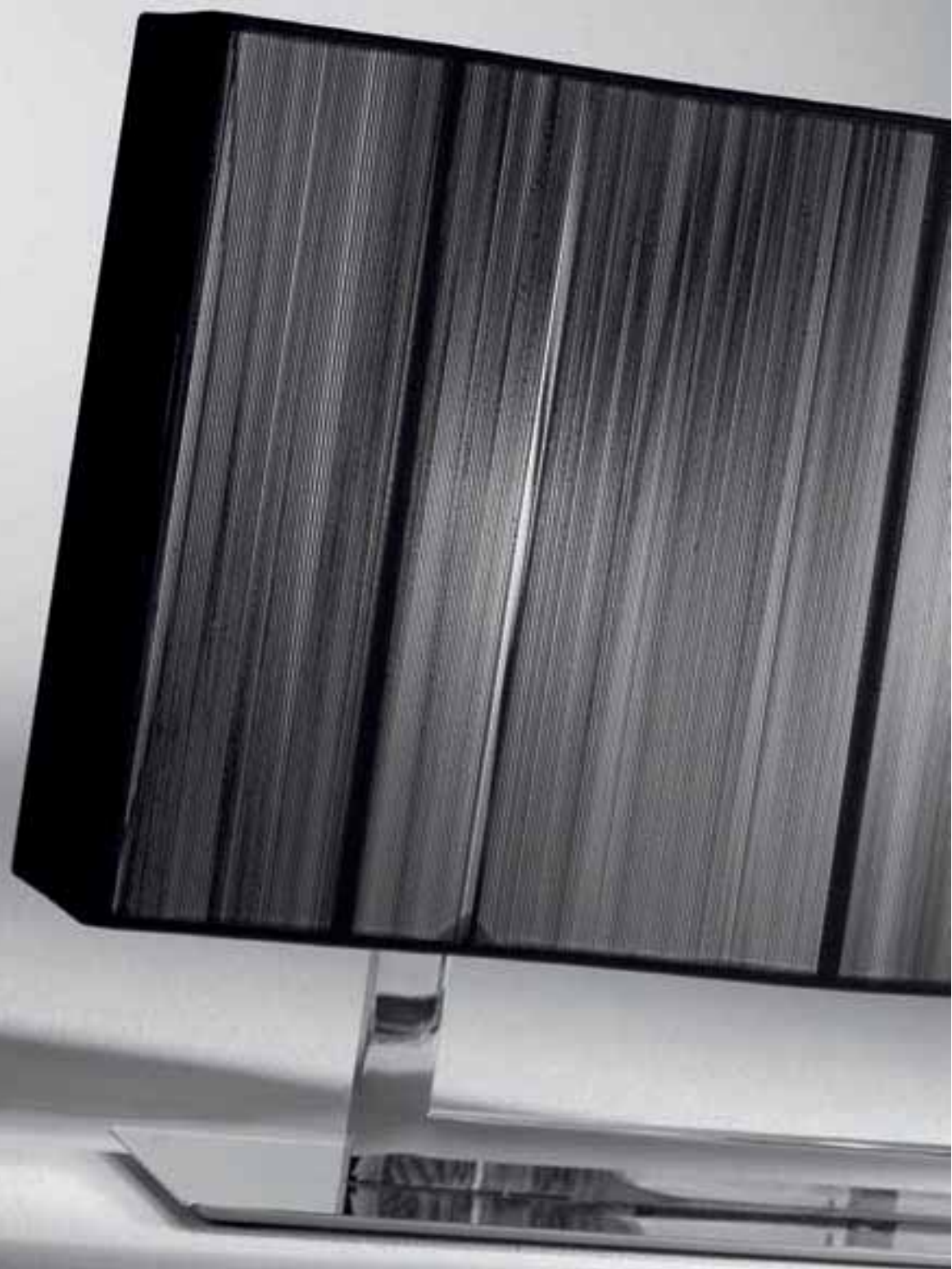





# KALEIDOLIGHT

---

DESIGN DODO ARSLAN

Lampada da tavolo in vetro specchiato semiriflettente e finiture metalliche in bagno d'oro. Lampadine fluorescenti incluse.

Table lamp in semireflecting mirrored glass with gold-dipped metal fittings. Fluorescent bulbs are included.

Tischleuchte aus halbdurchsichtigem Spiegelglas und goldfarbiger Metallstruktur. Leuchtstofflampen sind inbegriffen.

Lampe du table au semi-transparent verre-miroir et finitions en bain d'or. Ampoules fluorescent inclus.

Lámpara de mesa en vidrio espejado semi-reflectante y acabado en metal dorado. Bombillas fluorescentes incluidas.

Настольная лампа из зеркального полупрозрачного стекла. Металлическая структура в золоте. Шарообразные флуоресцентные лампочки включительно.



LT KALEID - 3 x max 7 w - FB  - 3 x E14 fluo

LT KALEID - 3 x max 7 w - FB  - 3 x E14, fluo







## KALEIDOLIGHT

**LT KALEID**  
3 x max 7 w  
FB   
3 x E14 fluo

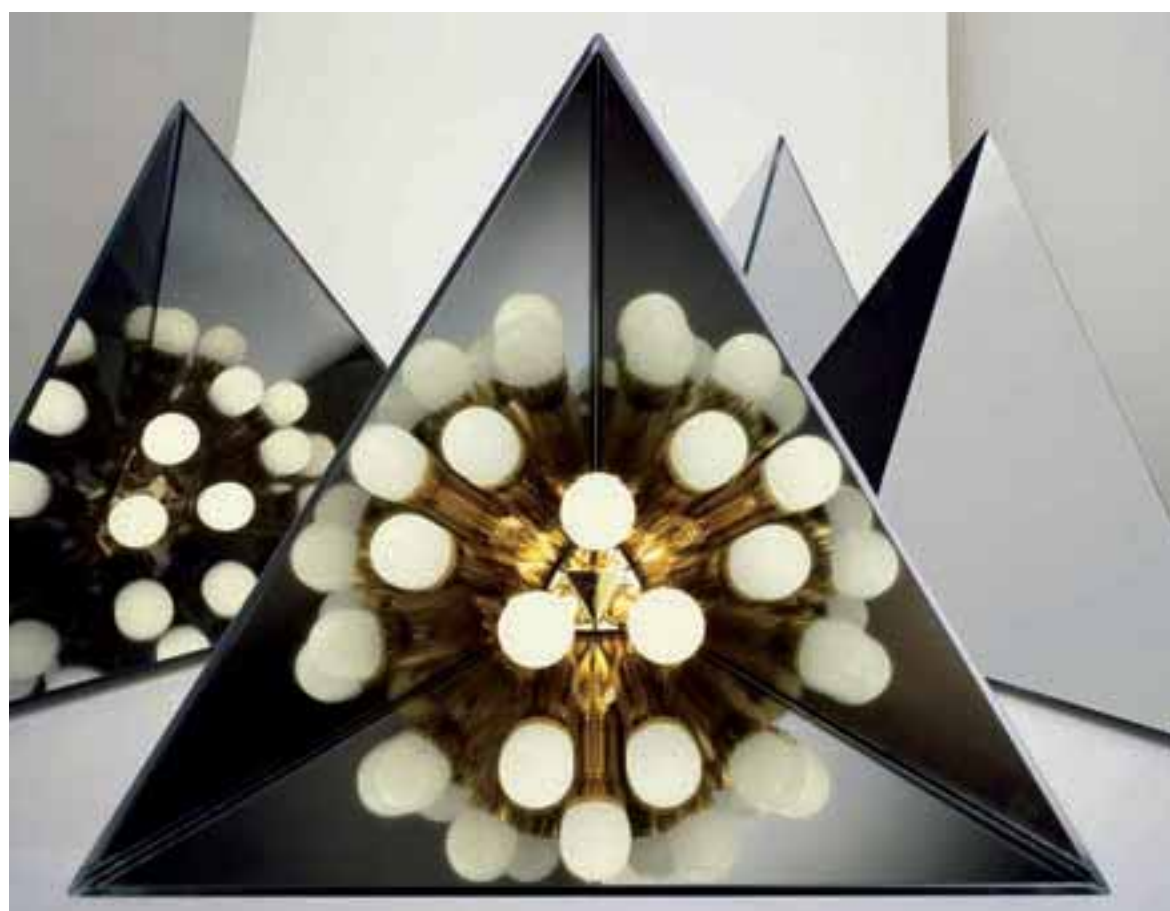

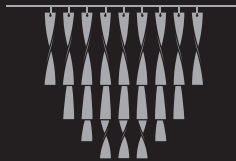
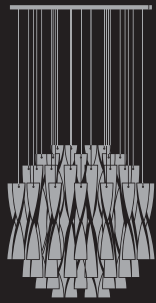



# AURA

---

## DESIGN MANUEL VIVIAN

Collezione Aura con pendenti in vetro colorato incamiciato cristallo e ritorti a mano. Finiture a soffitto in acciaio lucidato o foglia oro. Colori vetri: bianco, rosso, nero, arancio, tè e cristallo "rigadin".

Aura collection with double-layered coloured glass hand twisted pendants. Ceiling plates in polished steel or gold leaf. Glass available in white, red, black, orange, tea and ribbed crystal.

Kollektion Aura mit farbigen und kristallumhüllten Glaspendeln, die von Hand gezwirnt werden. Baldachin in Stahl oder Blattgold. Erhältliche Glasfarben; weiss, rot, schwarz, orange, teefarben und kristallklar mit Reliefstreifen.

Collection Aura avec des suspentes en verre coloré chemisé cristal et formés à la main. Finition acier chromé ou or vieilli à la feuille. Couleurs der verreries: blanc, rouge, orange, noir, thé et cristal avec relief.

Collección Aura con lagrimas en cristal de color soplado y retorcido a mano. Acabado del plafon en acero o dorado. Color del cristal: blanco, rojo, negro, naranja, te y cristal "rigadin".

Коллекция Aura с подвесками из цветного стекла, с прозрачной стеклянной облицовкой. Скрученные подвески ручной работы. Оправы светильников из глянцевой стали или покрыты золотой фольгой. Коллекция предлагается в следующей цветовой гамме: белый, красный, чёрный, оранжевый, чайный и муранское стекло "rigadin".

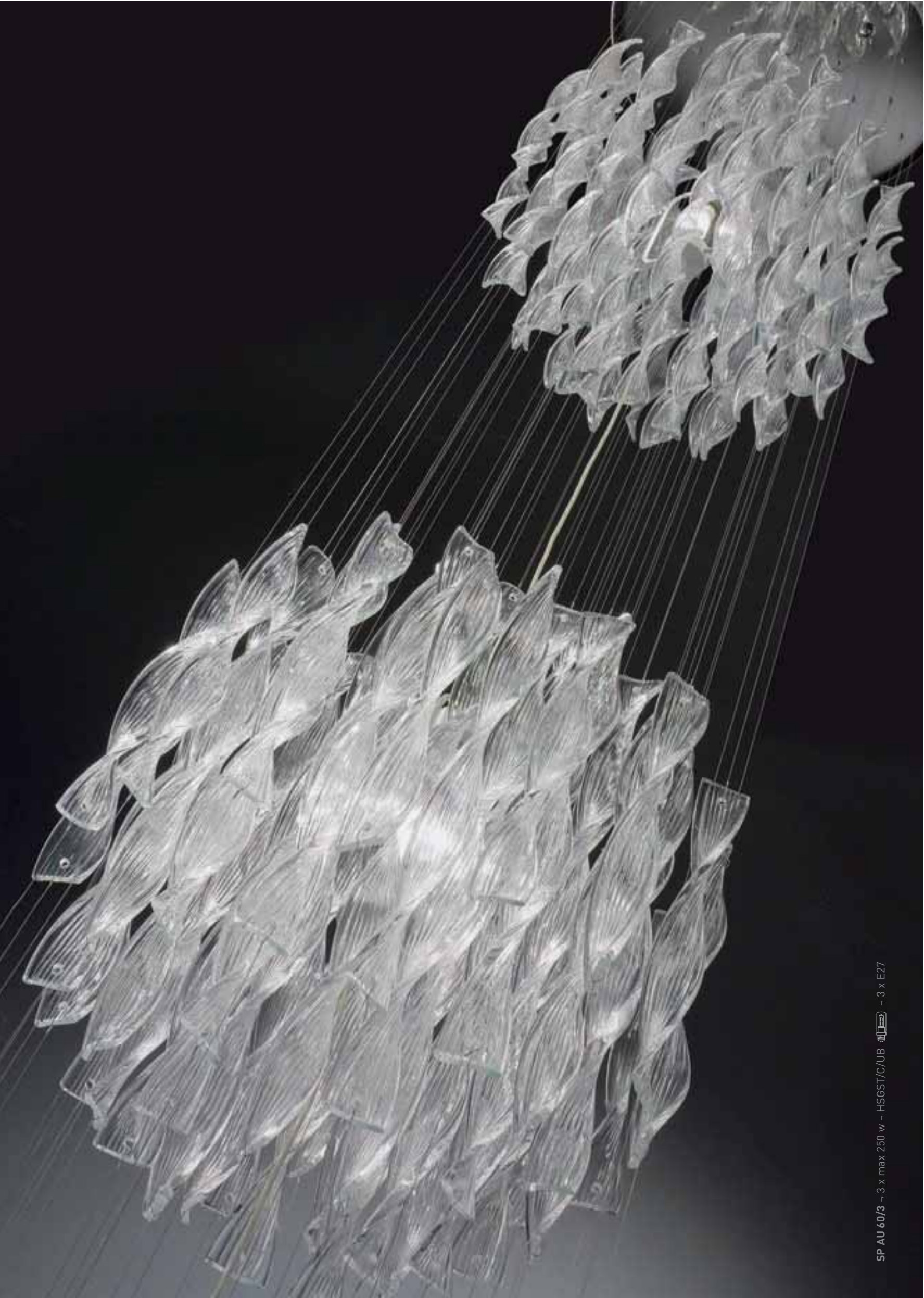



## AURA



### PL AURA GR

4 x max 100 w

HSGST/C/UB 

4 x E27

### < SP AU 60/3

3 x max 250 w

HSGST/C/UB 

3 x E27



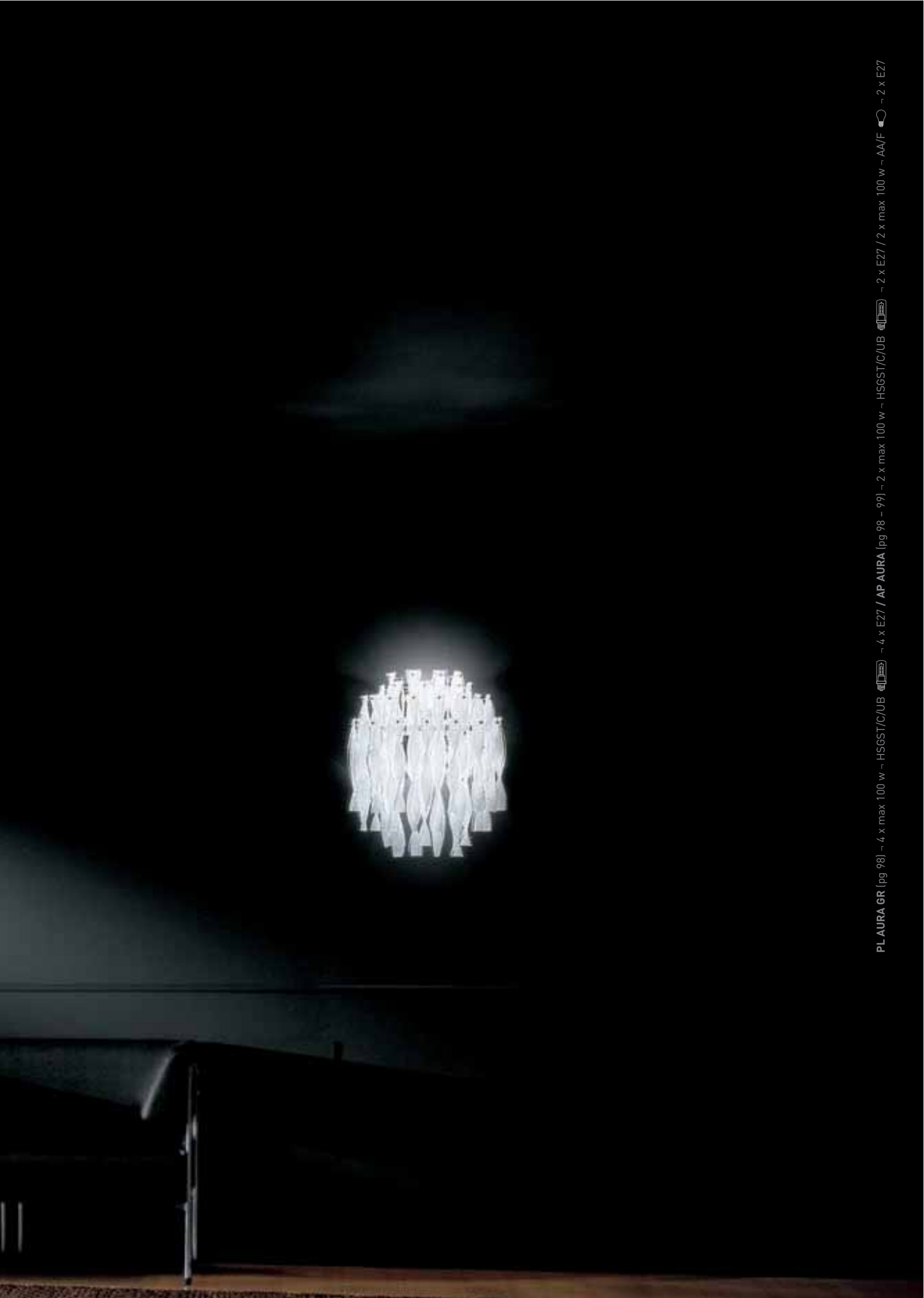

# AURA



**PL AURA GR >**  
4 x max 100 w  
HSGST/C/UB   
4 x E27

**PL AUR G 30**  
4 x max 100 w  
HSGST/C/UB   
4 x E27





# AURA

## SP AURA 60

1 x max 250 w

HSGST/C/UB 

1 x E27



# AURA

## FA AURA 44

1 x max 35 w

HAGS/UB 

1 x GU 5.3



## SP AU 60/2 >

2 x max 250 w

HSGST/C/UB 

2 x E27





# FALL IN LOVE

---

AION DESIGN

Lampada da tavolo in metacrilato bicolore bianco-giallo, ad alta diffusione della luce.

High-diffusion two-tone (white-yellow) methacrylate table lamps.

Tischleuchte, aus zweifarbigem Methacryl in weiß-gelb, große Lichtstreuung.

Lampe de table en "bi-méthacrylate" bicolore, intérieur Blanc-extérieur Jaune, à réflexion de lumière élevée.

Lámpara de mesa de metacrilato bicolor blanco-amarillo, con alta difusión de luz.

Настольная лампа из двухцветного бело-жёлтого метакрилата с высокой рассеивающей световой способностью.



LT FALLIN ~ 1 x max 150 w ~ IAA/F  ~ 1 x E27

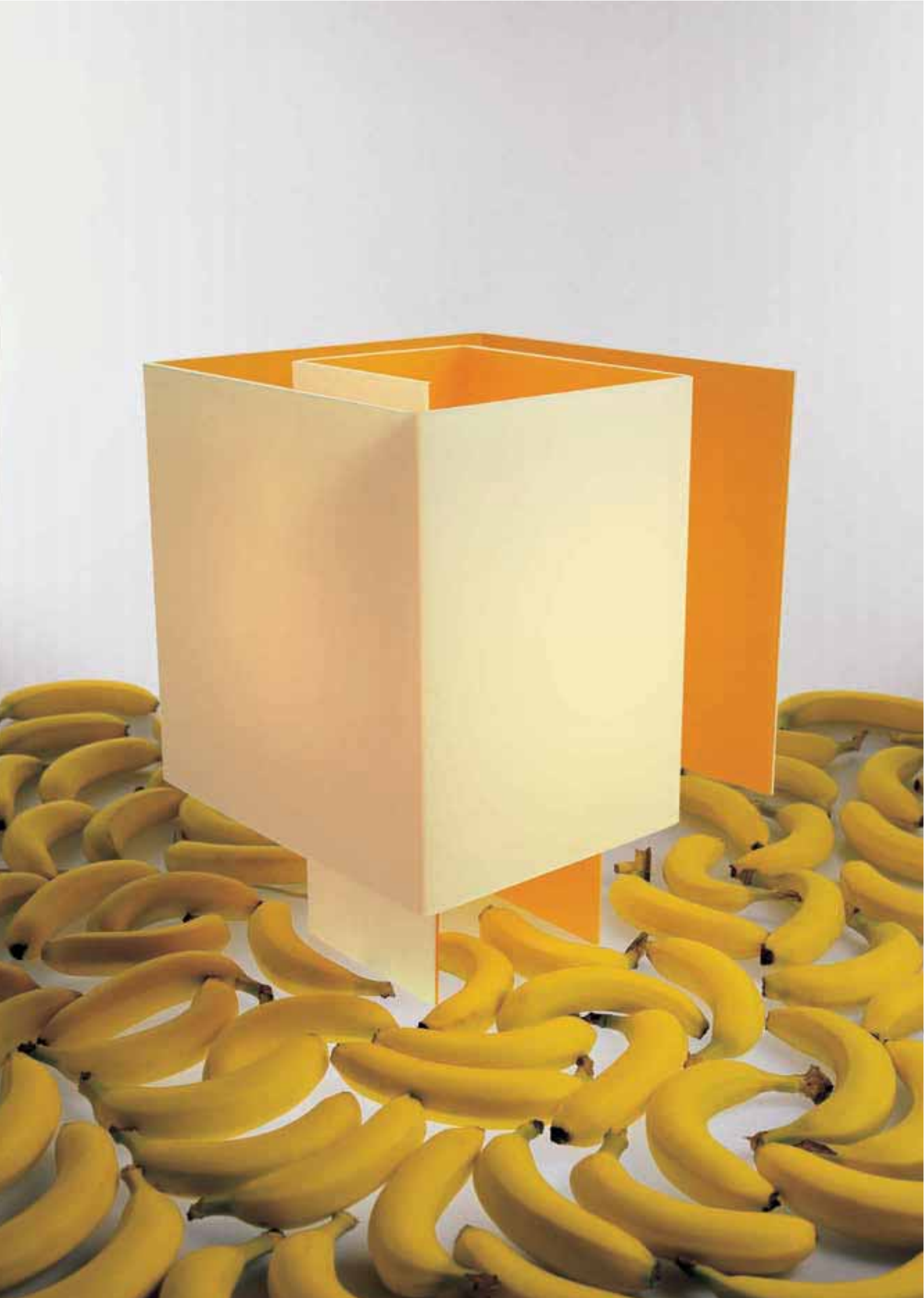

## FALL IN LOVE

**LT FALLIN**  
1 x max 150 w  
IAA/F   
1 x E27



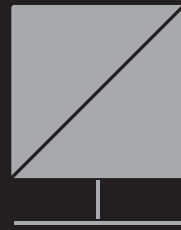
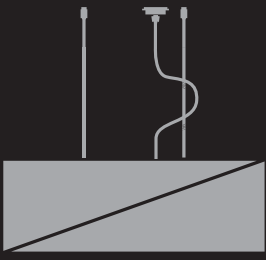

NELLY

---

# NELLY

---

DESIGN MANUEL VIVIAN

Collezione di lampade in tessuto elastico sfoderabile e lavabile.

Lamp collection made with coverings of removable and washable elastic fabric.

Kollektion aus elastischem, abnehmbarem Stoff. Waschbar.

Collection de lampes en tissu élastique déhoussable et lavable.

Colección de lamparas en tejido elástico desenfundables y lavables.

Коллекция ламп из снимающейся и моющейся эластичной ткани.



PT NELL 60 - 4 x max 100 w - IAA/F - 4 x E27





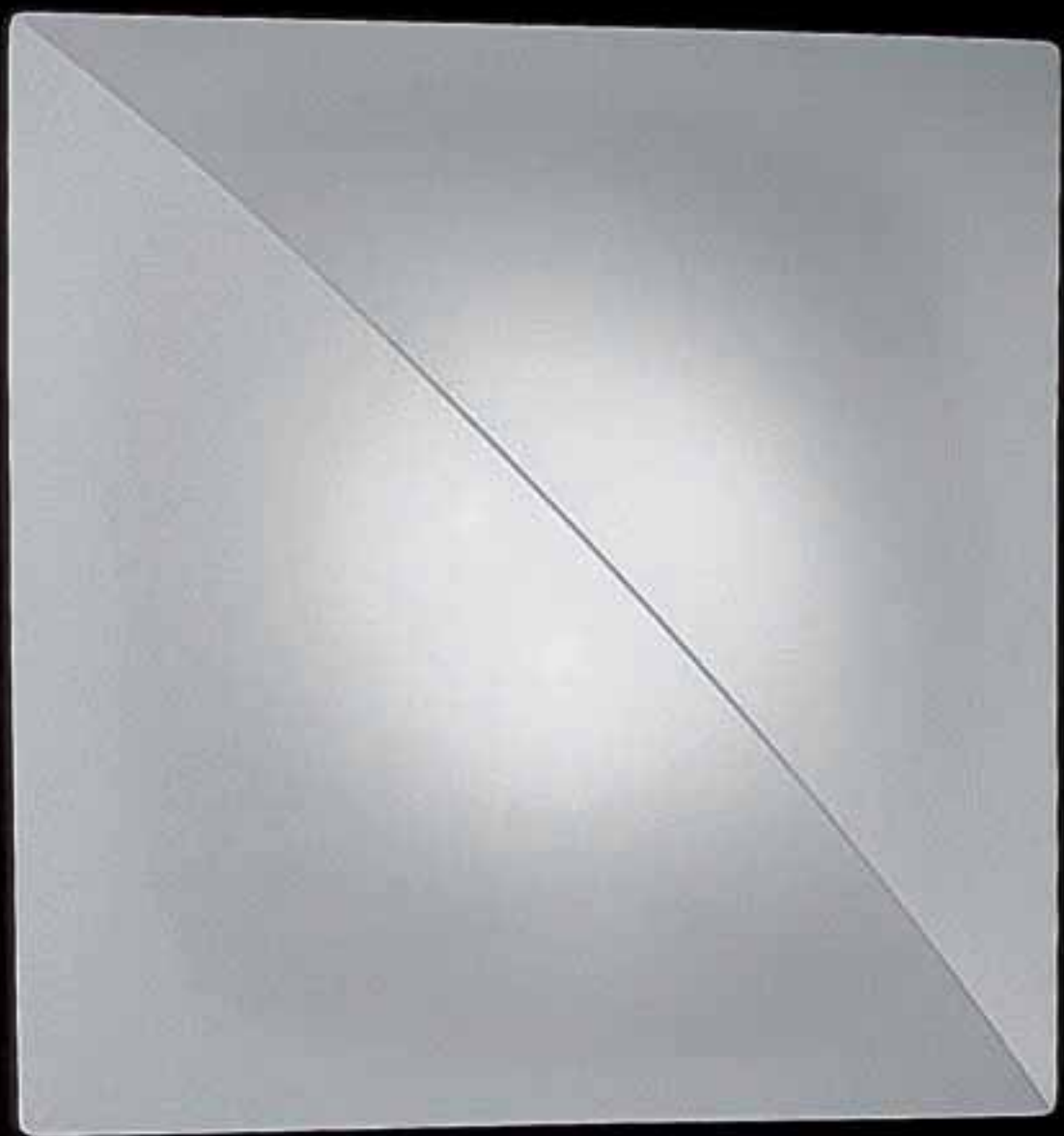



# NELLY



**PL NELL 60**  
2 x max 100 w  
IAA/F   
2 x E27

1 x max 55 w  
FSC   
1 x 2GX13



**PL NE Q 100**  
3 x max 100 w  
IAA/F   
3 x E27

1 x max 55 w  
FSC   
1 x 2GX13

# NELLY

**LT NELLY G**  
1 x max 100 w  
IAA/F   
1 x E27

**LT NELLY P**  
1 x max 60 w  
IBB/W   
1 x E14





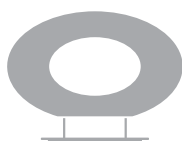
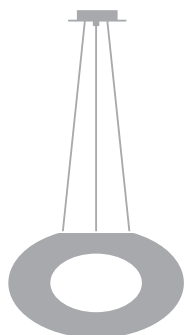

# BALL UP

DESIGN MANUEL VIVIAN

Collezione di lampade in vetro soffiato rosso, nero e vaniglia incamiciato bianco e lavorato a mano da maestri vetrai. Finiture metalliche cromate.

Lamp collection in red, black or vanilla glass with white interior, hand-made by master glassmakers. Chrome-plated fittings.

Eine von Glasmeistern mundgeblasene und handgearbeitete Leuchtenkugel in rot, schwarz oder vanille mit Innenauskleidung in weiß. Metallteile aus Chrom.

Collection de lampes en verre soufflé rouge, noir ou vanille intérieur verre soufflé blanc et fabriqué par des "Maîtres Verriers". Parties métalliques chromées.

Colección de lámparas de vidrio bufado rojo, negro o vainilla enfundado blanco y hecho a mano por maestros vidrieros. Acabados de metal cromado.

Коллекция светильников из дутого стекла, произведённая мастерами стеклодувами. Лампы предлагаются в следующей цветовой гамме: красный, чёрный и ванильного цвета с внутренней поверхностью белого цвета. Отделка из хромированного металла.



SP BALLUP ~ 1 x max 200 w ~ HDG (118) ~ 1 x R7s



## BALL UP

### SP BALLUP

1 x max 200 w

HDG (118) 

1 x R7s

### LT BALLUP

1 x max 150 w

HDG (118) 

1 x R7s







SP BALUP P ~ 1 x max 40 w ~ HSGST/C/UB  ~ 1 x G9

## BALL UP

**SP BALUP P**  
on / off



**SP BALUP P >**  
1 x max 40 w  
HSGST/C/UB   
1 x G9

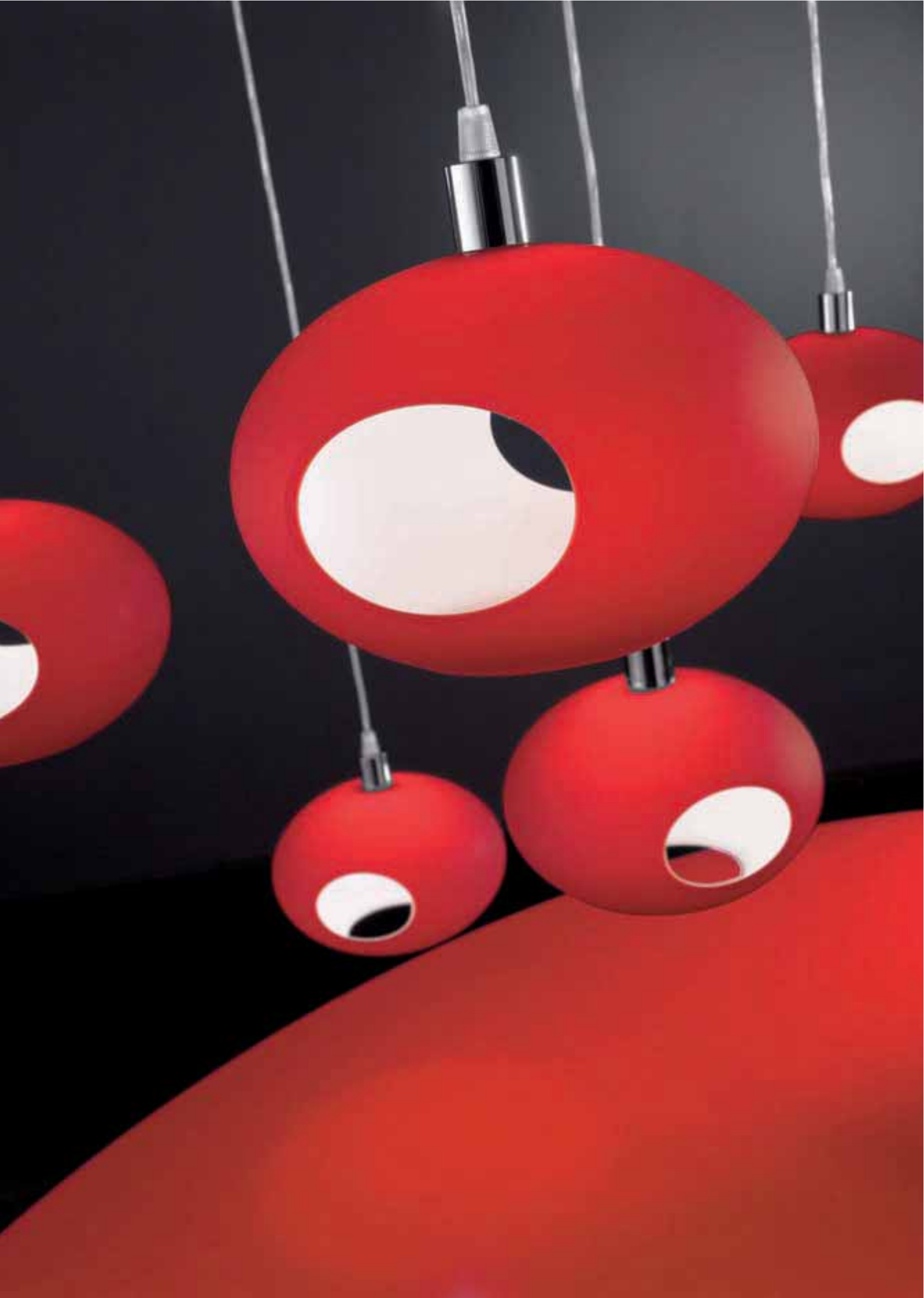

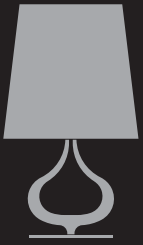
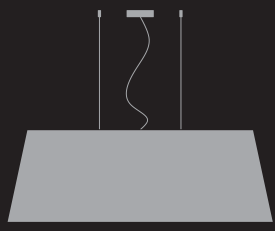

SLIGHT

---

# SLIGHT

---

## DESIGN MANUEL VIVIAN

Collezione di lampade da parete, da tavolo e sospensione in acciaio lucido e metacrilato, con paralumi in tessuto disponibili nei colori vaniglia o rosso.

Suspension, table and wall lamp collection in polished steel and methacrylate, with lampshades available in vanilla and red fabric.

Kollektion bestehend aus Wand-, Tisch- und Pendelleuchten mit Struktur aus glänzendem Stahl und Methacryl. Lampenschirme aus Stoff in den Farben vanillefarben und rot.

Collection de lampes du table, applique et suspension, structure en acier chromé et méthacrylate. Abat-jour couleur vanille et rouge.

Colección de lámparas de pared, de mesa y colgantes en acero lúcido y metacrilado, con pantallas en tejido disponibles en color vanilla o rojo.





Коллекция настенных, настольных и подвесных светильников, выполненных из глянцевой стали и метакрилата с абажуром из ткани красного и ванильного цвета.



LT SLIGH P ~ 1 x max 60 w ~ IBB/W ~ 1 x E14 / 1 x max 11 w ~ FBT ~ 1 x E14





LT SLIGHT G (pg 132) - 1 x max 100 w - IAA/F  - 1 x E27 / 1 x max 20 w - FBT  - 1 x E27 / SP SLIGHT (pg 133) - 2 x max 100 w - IAA/F  - 2 x E27 / 2 x max 20 w - FBA  - 2 x E27



## SLIGHT

### ◀ AP SLIGHT

1 x max 40 w

IBB/W 

1 x E14

1 x max 9 w

FBB 

1 x E14

### LT SLIGH G

1 x max 100 w

IAA/F 

1 x E27

1 x max 20 w

FBT 

1 x E27



AP SLIGHT (pg 136) - 1 x max 40 w - IBB/W - 1 x E14 / 1 x max 9 w - FBB - 1 x E14 / 1 x max 100 w - IAA/F - 2 x E27 / 2 x max 20 w - FBA - 2 x E27





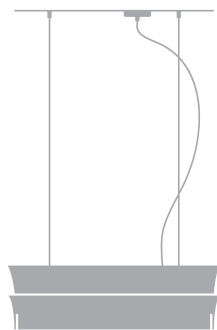

# BALIOS

DESIGN MANUEL VIVIAN

Collezione di lampade in vetro nelle applicazioni a parete e sospensione, disponibili nei colori bianco, caffè, cromo e loro composizioni, finiture in metallo cromato.



Glass suspension and wall lamp collection; available in white, coffee, chrome or combinations. Chrome-plated fittings.

Glaskollektion mit Hängeleuchte und Wandleuchte in weiß, kaffee, chrom oder zwei von genannten Farben mit verchromtem Armatur.

Collection de lampes en verre pour les applications murales et suspendues; disponible dans les tons blanc, café, chrome et leurs compositions; finitions en métal chromé.

Colección de lámparas en vidrio para pared y colgantes, disponibles en color blanco, café, cromo y sus composiciones, acabados de metales cromados.

Коллекция ламп из стекла, состоящая из двух вариантов: бра и подвесный светильник. Лампы предлагаются в следующей цветовой гамме: белый, кофейный, хромированный и комбинированный цвет. Оправа из хромированного металла.

SP BALLIOS - 2 x max 39 w - FDH  - 2 x G5 / AP BALLI 60 - 3 x max 60 w - HDG [78]  - 3 x R7s / 2 x 24 w - FDH  - 2 x G5





## BALIOS



### AP BALI 25

1 x max 100 w

HDG (78) 

1 x R7s

### AP BALI 60

3 x max 60 w

HDG (78) 

3 x R7s

2 x 24 w

FDH 

2 x G5

### SP BALIOS

2 x max 39 w

FDH 



2 x G5

# BALIOS



**SP BALIOS**  
2 x max 39 w  
FDH   
2 x G5



**AP BALI 60**  
3 x max 60 w  
HDG (78)   
3 x R7s  
  
2 x 24 w  
FDH   
2 x G5





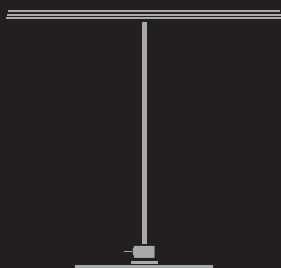

LEDGE

---

# LEDGE

---

## DESIGN MANUEL VIVIAN

Collezione di lampade in metallo cromato e metacrilato colorato. Modulo lineare LED ad alta intensità incluso nel prezzo. Finiture disponibili nei colori cromo, bianco e rosso.

Methacrylate and chrome-plated lamp collection. High performance linear LED module is included in the price. Available with chrome, white or red fittings.

Leuchtenkollektion aus verchromten Metall und farbigem Methacryl. HighPerformance LED Linienmodule im Preis inbegriffen. Erhältlich in folgenden Farben: Chrom, weiss und rot.

Collection de lampes en métal chromé et méthacrylate coloré. High performance LED module linéaire compris. Disponible en couleurs chromé, blanc et rouge.

Collección en metal cromo y metacrilato colorado. High performance LED lineal módulo incluido en el precio. Disponible en los colores cromo, blanco y rojo.

Коллекция светильников из хромированного металла и цветного метакрилата. Линейный элемент LED с высокой энергоинтенсивностью включён стоимость. Отделки предлагаются в хромированном, белом и красном цвете.

LT LEDGE - 1 x max 12 w - hp linear led module





## LEDGE

**AP LEDGE**  
1 x max 12 w  
hp linear led module



## LEDGE

### AP LEDGE >

1 x max 12 w  
hp linear led module



### LT LEDGE

1 x max 12 w  
hp linear led module

### SP LEDGE >

1 x max 12 w  
hp linear led module





# EXTREME

---

## DESIGN MANUEL VIVIAN

Applique in vetro piano multistrato satinato con parti metalliche cromate e vetri di protezione in pyrex satinato. Disponibile nella versione in pietra di Vicenza bianco avorio.

Wall lamp made in flat satin-finished multilayered glass with chrome-plated metal parts and pyrex satin-finished protective glass. Also available in ivory-white natural Vicenza stone.

Leuchtenfamilie aus satiniertem oder farbigem Schicht-Glas. Diese Kollektion ist auch aus NATURSTEIN lieferbar.

Applique en verre multicouches satiné avec parties métalliques chromées et verres de protection en pyrex satiné. Disponible dans la version en pierre de Vicence blanc ivoire.

Applique en vidrio multiestrato satinado con partes metálicas cromadas y vidrios de protección en pyrex satinado. Disponible en el modelo de piedra de Vicenza blanco avorio.

Бра из многослойного сатинированного стекла с хромированными элементами и с защитными стеклами из сатинированного pyrex. Предлагаются также и в варианте Вичентийского камня цвета слоновой кости.





## EXTREME

### AP EXTR 40 CS (detail)

1 x max 100 w

HDG (118) 

1 x R7s



### < AP EXTR 60 PI

2 x max 150 w

HDG (118) 

2 x R7s



LOLLO

---

# LOLLO

---

## DESIGN MANUEL VIVIAN

Collezione completa di lampade con parti metalliche in nichel opaco e paralumi in fili setati lavorati a mano. Placche a muro e basi disponibili anche in legno.

Lamp collection with mat nickel frame and handmade silken thread lampshades. Wall plaques and bases are also available in wood.

Leuchtenfamilien nickelmatt mit handgearbeiteten Lampenschirmen aus Seidenfäden. Wand--Fußplatten auch aus Holz lieferbar.

Collection complète de lampes avec parties métalliques en nickel opaque et abat-jours en fils de soie fabriqués à la main. Plaques murales et bases également disponibles en bois.

Colección completa de lámparas con partes metálicas en níquel opaco y pantallas en hilo de seda realizadas a mano. Placas de pared y bases disponibles también en madera.

Коллекция ламп с металлическими частями из матового никеля. Абажур выполнен из шелковидных нитей ручной работы. Настенные пластины и базы могут быть выполнены также и из дерева.



SP LOLLÒ - 1 x max 100 w - IAA/F - 1 x E27



## LOLLO

### < AP LOLLO 1 B

1 x max 40 w

IBB/W 

1 x E14



### AP LOLLO

1 x max 100 w

IAA/F 

1 x E27

### < LT LOLLO P

1 x max 40 w

IBB/W 

1 x E14

# LOLLO

**PT LOLLO** >  
2 x max 100 w  
IAA/F   
2 x E27



**LT LOLLO G**  
2 x max 100 w  
IAA/F   
2 x E27





# KORE

---

AION DESIGN

Collezione di lampade da parete in vetro o acciaio disponibili nei colori bianco satinato o acciaio lucido.

Wall lamp collection in glass or steel. Available in white satin-finished glass or polished steel.

Kollektion von Wandleuchten aus Glas oder Stahl in weiss oder glanzender Stahl lieferbar.

Collection de lampes murales en verre ou acier disponibles en blanc ou acier chromé.

Colección de lámparas de pared en vidrio o acero disponibles en blanco o acero.

Коллекция настенных ламп из стекла или из стали. Предлагаются в сатинированном белом цвете или цвета глянцевой стали.



# KORE

## AP KORE 40 >

1 x max 150 w

HDG (118) 

1 x R7s

1 x max 18 w

FSMH 

1 x GX24q-2



## AP KORE 60

1 x max 200 w

HDG (118) 

1 x R7s

2 x max 24 w

HDG (118) 

2 x 2G11



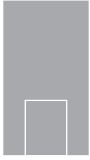

# JAZZ

DESIGN PAOLA FACHIN, ROBERTO VIVIAN

Collezione di lampade in vetro bianco satinato.  
Parti metalliche laccato grigio.



Lamp collection made of white satin-finished  
glass. Grey enameled metal parts.

Leuchtenkollektion mit weißer Glasscheibe.  
Metallteile grau lackiert.

Collection de lampes en verre plat blanc satiné.  
Parties métalliques laquées grises.

Colección de lámparas en vidrio plano blanco  
satinado. Partes metálicas laqueado gris.

Коллекция ламп из сатинированного белого  
стекла. Металлические элементы выполнены  
в лакированном сером цвете.

AP JAZZ - 2 x max 60 w - IBB/W  - 2 x E14 / 2 x max 18 - FSQ  - 2 x G24d-2 / 2 x max 18 elektr - FSQ  - 2 x G24q-2



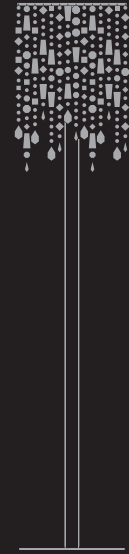
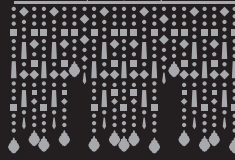
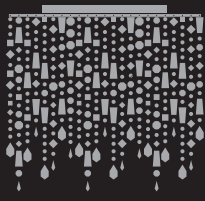

MARYLIN

---

# MARYLIN

---

DESIGN MANUEL VIVIAN

Collezione con pendenti in cristallo al piombo e parti in nichel satinato. Disponibile nei colori cristallo o nero.

Collection with lead crystal pendants and mat nickel parts. Available in clear or black crystal.

Kollektion aus nickel matt und Anhängern aus Bleikristall Erhältlich in transparentkristall oder schwarz.

Collection avec pendentifs en cristal au plomb et parties en nickel satiné. Disponible dans les tons cristal ou noir.

Colección con colgantes de cristal de plomo y partes en níquel satinado. Disponible en color cristal o negro.

Коллекция с подвесками из хрустала и отделкой из сатинированной никелировки. Лампы предлагаются в прозрачном и чёрном варианте.



# MARYLIN

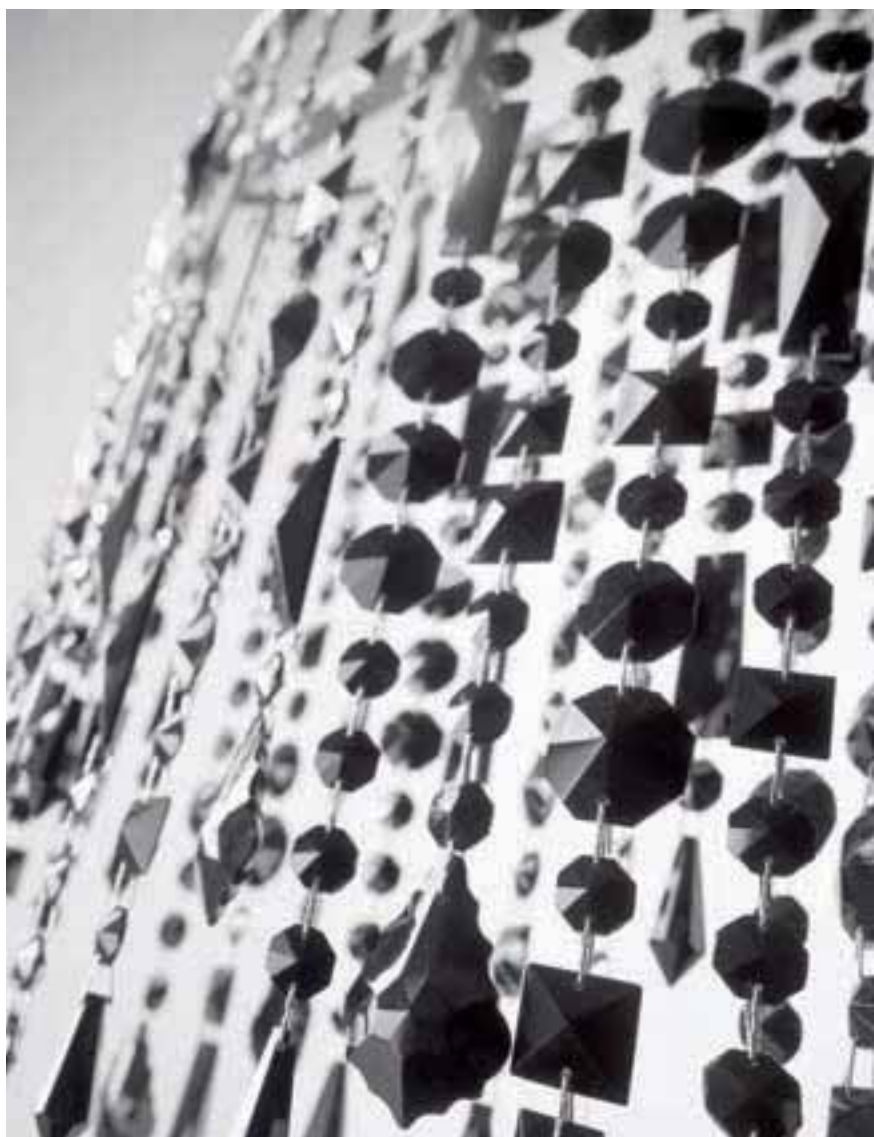

**SP MARY 36**  
1 x max 60 w  
HSGST/C/UB   
1 x G9



AP MARYLI (pg 176) - 1 x max 60 w - IAA/C - 1 x E27 / SP MAR 100 (pg 177) - 6 x max 60 w - HSGST/C/JUB - 6 x G9







# MARYLIN



## FA MARYLI

1 x max 35 w

HAGS/UB 

1 x GU 5.3

## PL MARY 66

4 x max 60 w

HSGST/C/UB 

4 x G9



## ◀ SP MARYL P

1 x max 40 w

HSGST/C/UB 

1 x G9

## ◀ PT MARYLI

1 x max 150 w

IAA/C 

1 x E27

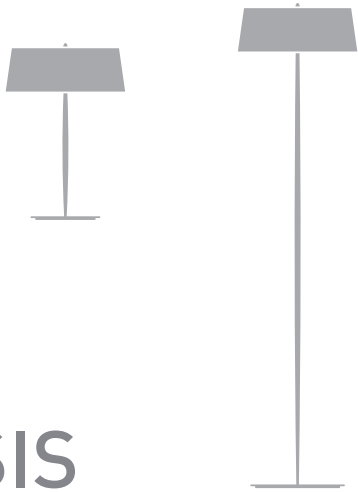
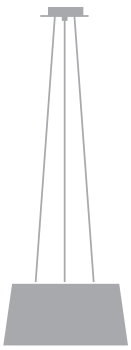

# ENTASIS

DESIGN MANUEL VIVIAN

Collezione di lampade in vetro soffiato nei colori rosso, bianco e nero con finitura in metallo cromato. Disponibili nelle applicazioni da tavolo, da terra e sospensione.

Lamp collection in blown glass with chrome-plated structure available in red, white or black. Suspension, table and wall lamp versions.



Kollektion aus geblasenem Glas mit Tischenleuchte, Stehleuchte und Hängeleuchte. In rot, weiß und schwarz, mit Armatur aus verchromtem Metall.

Collection de lampes en verre soufflé dans les tons rouge, blanc et noir avec finitions en métal chromé. Disponible pour les applications sur table, au sol et en suspension.

Colección de lámparas en vidrio soplado en color rojo, blanco y negro con acabado en metal cromado. Disponible en las lámparas de mesa, de piso y colgantes.

Коллекция ламп из дутого стекла в следующей цветовой гамме: красный, белый и чёрный. Оправа из хромированного металла. Имеются в варианте настольных, напольных и подвесных светильников.



SP ENTASI ~ 1 x max 100 w ~ IAA/F  ~ 1 x E27 / PT ENTASI ~ 3 x max 60 w ~ IBB/W  ~ 3 x E14

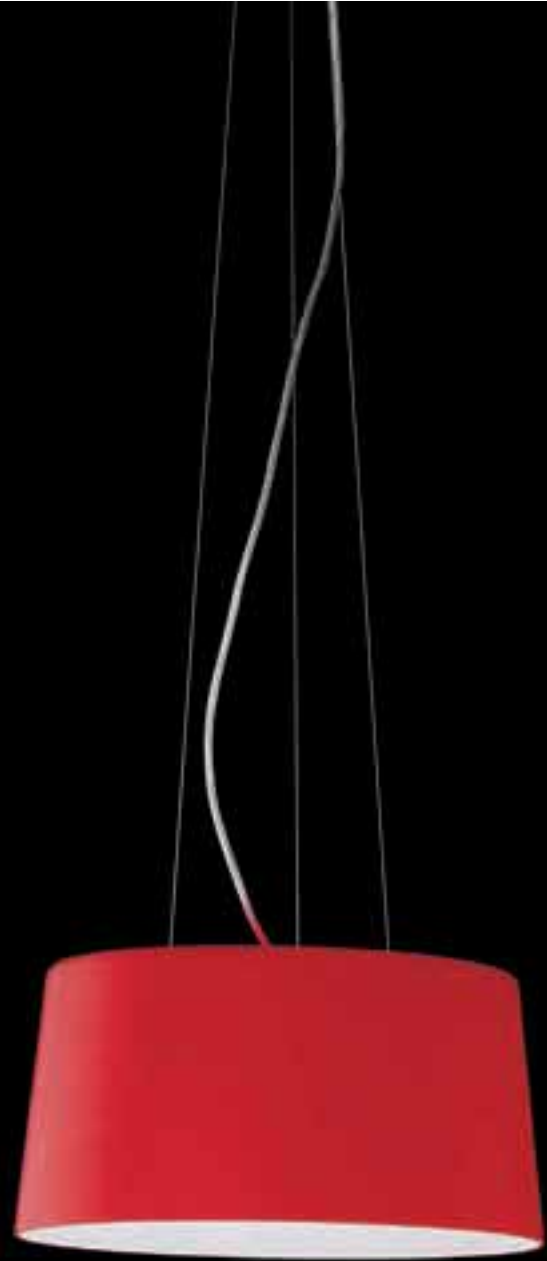
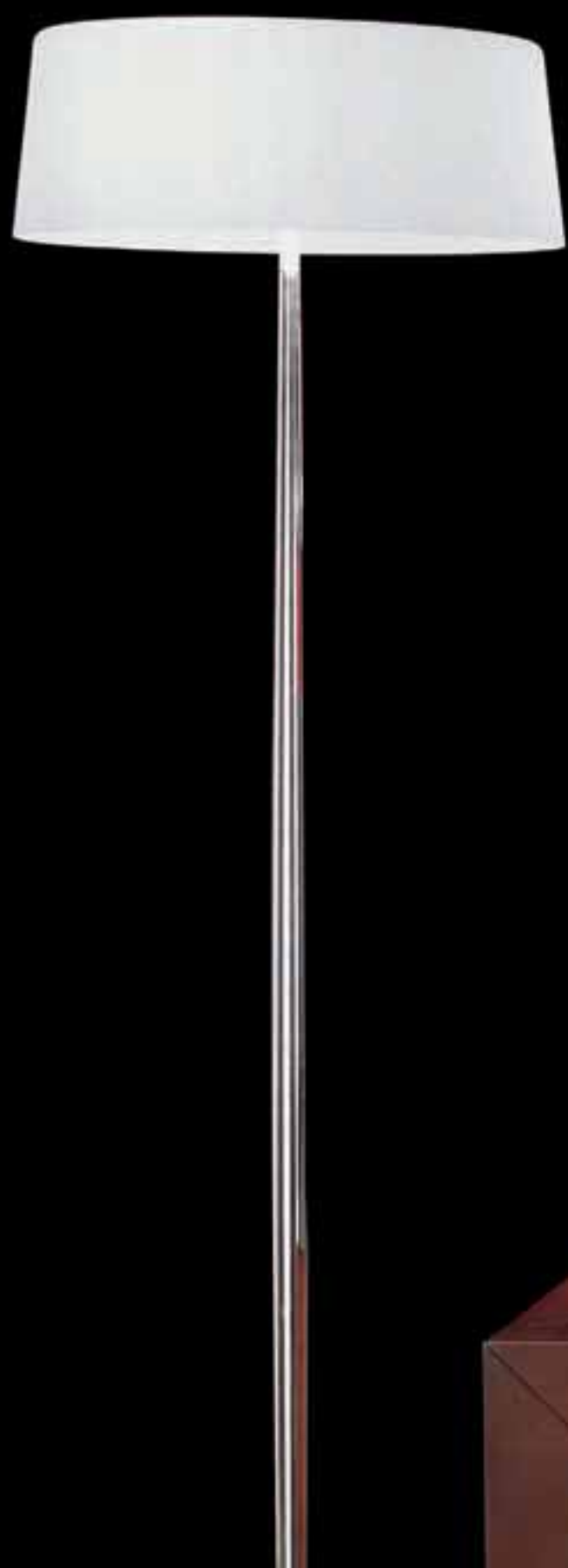

## ENTASIS

### SP ENTASI

1 x max 100 w

IAA/F 

1 x E27



### LT ENTASI

3 x max 40 w

IBB/W 

3 x E14



### < PT ENTASI

3 x max 60 w

IBB/W 

3 x E14



# ARI

---

DESIGN MANUEL VIVIAN

Faretti ad incasso con pendagli in vetro lavorato a mano disponibili nei colori cristallo, rosso e nero.

Recessed spotlights with handmade glass pendants available in clear crystal, red or black.

Einbauspots bestückt mit handgefertigten Glaspendeln, erhältlich in den Farben transparentkristall, rot und schwarz.

Spots à encastrer avec pendentifs en verre fabriqués à la main, disponibles dans les tons cristal, rouge et noir.

Faros empotrados con colgantes en vidrio realizado a mano disponible en color cristal, rojo y negro.

Вмонтированные лампы с подвесками из стекла ручной работы. В ассортименте имеются прозрачный, красный и чёрный цвет.



FA ARI G ~ 1 x max 35 w ~ HAGS/UB ~ 1 x GU 5.3



# ARI

## ◀ FA ARI G

1 x max 35 w

HAGS/UB △

1 x GU 5.3

## FA ARI P

1 x max 35 w

HAGS/UB △

1 x GU 5.3





# KROM

DESIGN MANUEL VIVIAN, MAX VIVIAN

Applique in pietra di Vicenza bianco avorio.

Ivory white natural Vicenza stone wall lamp.

Wandleuchte aus Vicenza Naturstein,  
elfenbeinfarben.

Applique en pierre de Vicence Blanc ivoire.

Applique en piedra de Vicenza blanco avorio.

Бра из Вичентийского камня цвета слоновой  
кости.



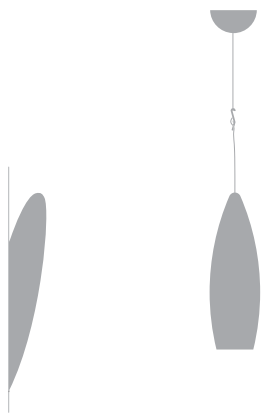

# BORA

---

## DESIGN MANUEL VIVIAN

Collezione di lampade in vetro soffiato triplex nelle applicazioni a sospensione e a parete; disponibile nei colori ambra, bianco, rosso e nero; finiture in metallo cromato.

Triplex blown glass suspension and wall lamp collection. Available in amber, white, red and black; chrome-plated fittings.

Kollektion aus geblasenem Triplexglas mit Hängeleuchte und Wandleuchte in bernsteinfarbig, weiß, rot und schwarz. Armatur aus verchromtem Metall.

Collection de lampes en verre soufflé triplex pour les applications suspendues et murales; disponible dans les tons ambre, blanc, rouge et noir; finitions en métal chromé.

Colección de lámparas en vidrio soplado triplex en los apliques colgantes y de pared; disponibles en color ambra, blanco, rojo y negro; con acabados en metal cromado.

Коллекция ламп из дутого тройного стекла. Предлагаются в подвесных и настенных вариантах. Цвета: янтарный, белый, красный и чёрный. Оправа из хромированного металла.





# BORA

## ◀ AP 10

1 x max 100 w

IAA/F 

1 x E27

1 x max 23 w

FBT 

1 x E27

1 x max 18 w

FSQ 

1 x G24d-2

## SP 10

1 x max 100 w

IAA/F 

1 x E27

1 x max 23 w

FBT 

1 x E27

only black colour

1 x max 50 w

HAGS/UB/30 

1 x E27

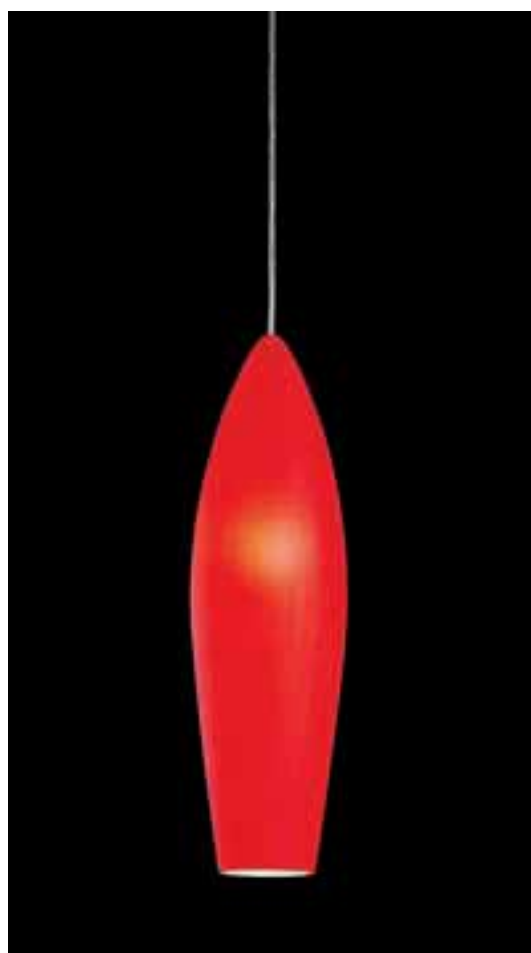



# CLARA

DESIGN MICHAEL NEUMAYR

Collezione di lampade con paralume in porcellana vetrosa satinata e finiture in frassino verniciato wengé. Finiture metalliche in nickel satinato.

Lamp collection with a satin-finished vitreous porcelain lampshade and wengé painted ash trim. Satin-finished nickel fittings.

Leuchtenkollektion mit Lampenschirm aus satiniertem Glasporzellan, Ausführung in Eschenholz, Wengé-lackiert. Metallteile aus satiniertem Nickel.

Collection de lampes avec abat-jour en porcelaine translucide satinée et finitions en frêne verni wengé et parties métalliques en nickel satiné.

Colección de lámparas con pantalla de porcelana vítrea satinada y acabados de haya barnizado wengue. Acabados de meta de níquel satinado.

Коллекция светильников с абажуром из сатинированного стекловидного фарфора и с отделкой из ясеня, обработанной методом венге. Металлическая оправа с сатинированной никелировкой.

AP CLARA H - 1 x max 40 w - HSGST/C/UB  - 1 x G9





## CLARA

### ◀ AP CLARA Q

1 x max 40 w

HSGST/C/UB 

1 x G9

### AP CLARA H

1 x max 40 w

HSGST/C/UB 

1 x G9



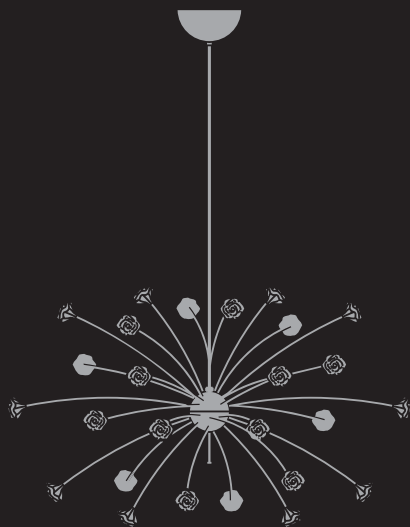

SHIRAZ

---

# SHIRAZ

---

## DESIGN MANUEL VIVIAN

Collezione con rose in cristallo di Boemia trasparenti o rosse e finiture in metallo cromato. Plafoniera, applique e faretto ad incasso in vetro temperato e serigrafato bianco.

Collection with clear or red Bohemian crystal roses and chrome-plated fittings. Ceiling, wall lamps and recessed spotlights come in white screen-printed tempered glass.

Wand-/Deckenleuchte und Einbauspots mit gehärtetem, weiß satiniertem Glas. Rosendekoration aus böhmischem Kristallglas in transparent oder rot.

Collection avec roses en cristal de Bohème transparent ou rouge et finitions en métal chromé. Plafonnier, applique et spot à encastrement en verre trempé et sérigraphé blanc.

Colección con rosas en cristal de Bohemia transparentes o rojas con acabados en metal cromado. Plafon, aplique y foco empotrado en vidrio templado y serigrafiado blanco.

Коллекция с прозрачными или красными розами, выполненными из богемского хрусталя. Отделка из хромированного металла. Плафон, бра и вмонтированные лампы из темпированного и сериграфированного стекла.

SP SHIR 18 ~ 18 x max 10 w ~ HSGST/UB  ~ 18 x G4









# SHIRAZ

## PL SHIRA G

1 x max 200 w

HDG (118) 

1 x R7s



## PL SHIRA M

1 x max 150 w

HDG (118) 

1 x R7s

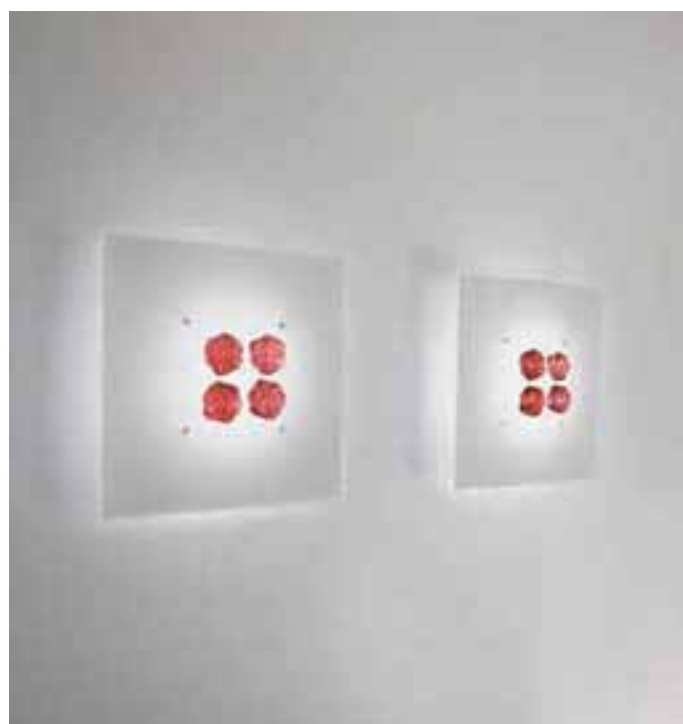

## < FA SHIRAZ

1 x max 35 w

HAGS/UB 

1 x GU 5.3

## SHIRAZ

### PL SHIRA P >

1 x max 60 w

HDG (78) 

1 x R7s



### LT SHIRAZ

18 x max 10 w

HSGST/UB 

18 x G4





PRIMULA

---

# PRIMULA

---

DESIGN MANUEL VIVIAN, MAX VIVIAN

Collezione completa di lampade in cristallo senza piombo e particolari in metallo tornito cromato.

Lamp collection made in pure crystal (no lead) with polished chrome-plated details.

Leuchtenfamilie aus transparentem Kristallglas. Metallteile chrom.

Collection complète de lampes sans plomb et détails en métal poli chromé.

Colección completa de lámparas en cristal sin plomo y detalles en metal torneado cromado.

Коллекция из хрусталя без свинца. Отделки из обточенного хромированного металла.





## PRIMULA



### < AP PRIMU 1

1 x max 35 w

HSGST/UB 

1 x GY 6.35

### PL PRIMU 4

4 x max 35 w

HSGST/UB 

4 x GY 6.35

# PRIMULA

## AP PRI 1 BR

1 x max 35 w

HSGST/UB 

1 x GY 6.35

## PL PRIMU 1

1 x max 35 w

HSGST/UB 

1 x GY 6.35

## FA PRIMUL >

1 x max 35 w

HSGST/UB 

1 x GU 6.35



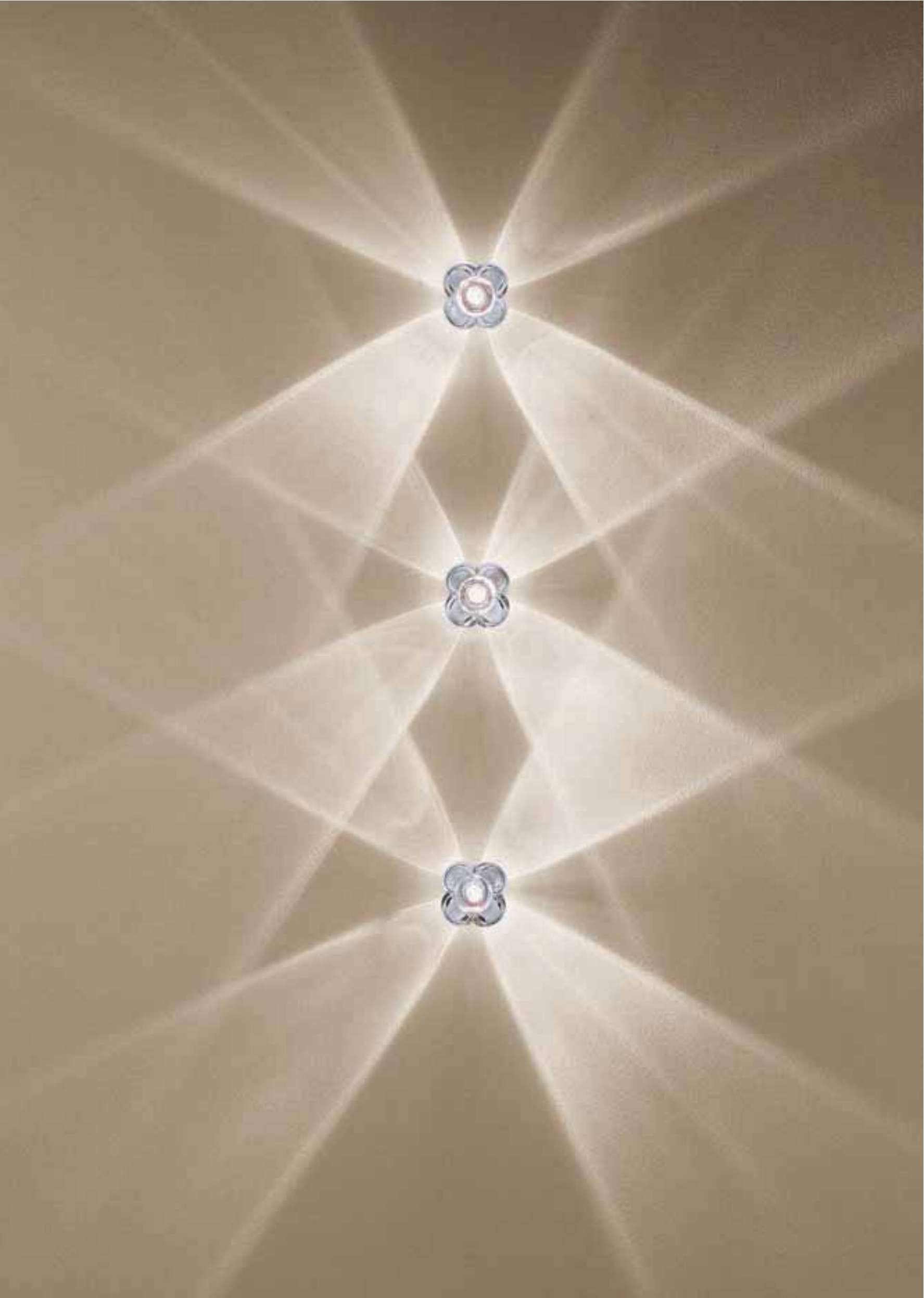



# ALEA

---

DESIGN MANUEL VIVIAN

Lampada da parete in vetro e finiture cromate.

Glass wall lamp with chrome-plated fittings.

Wandleuchte aus Glas mit Chromplatte.

Lampe murale en verre avec finitions chromées.

Lámpara de pared en vidrio y acabados cromados.

Настенная лампа из стекла с хромированной оправой.

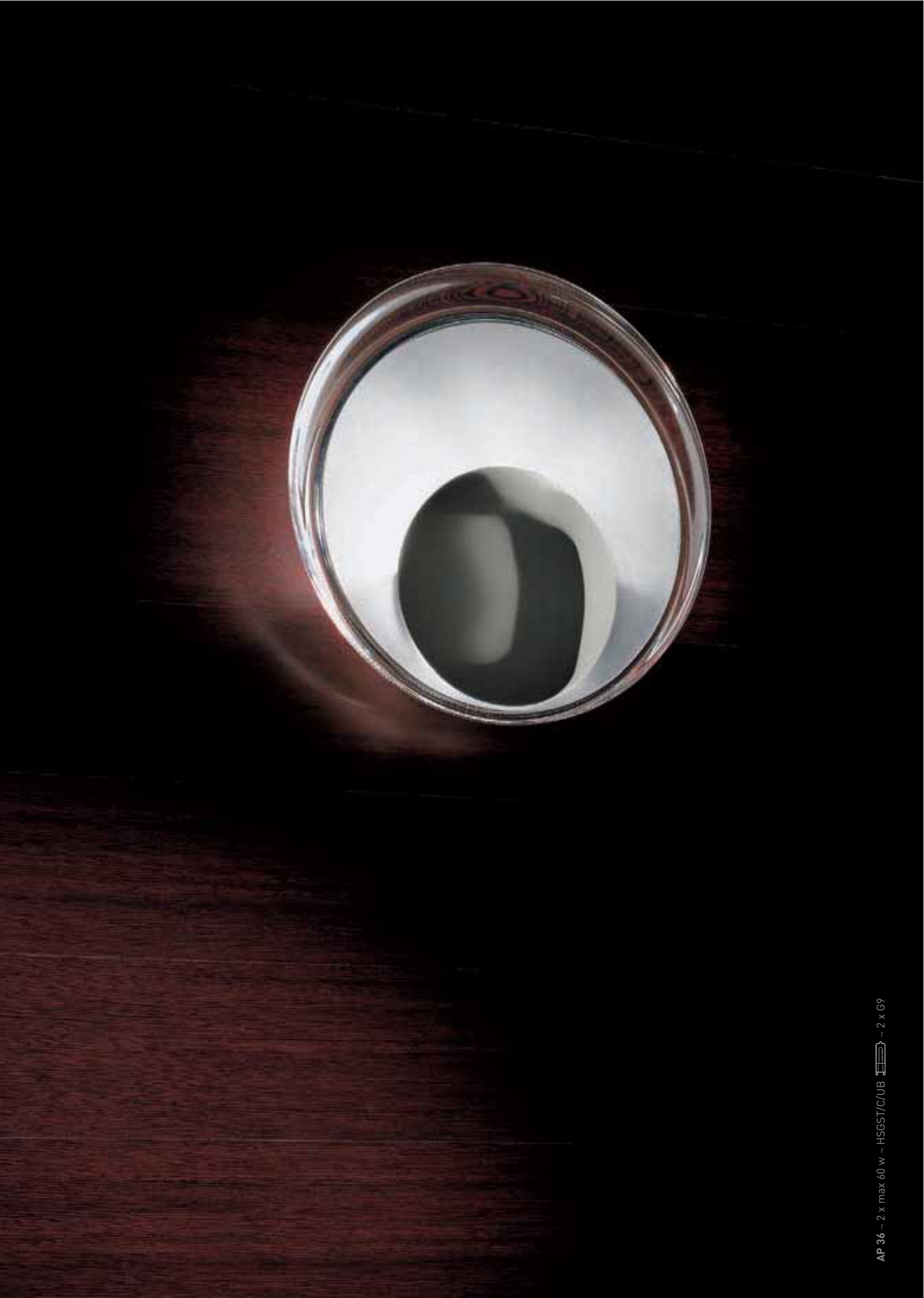



# CRYSTAL SPOTLIGHT

---

DESIGN STUDIO TECNICO

Collezione di faretti in pregiato cristallo di Bohemia e finitura in metallo.

Spotlight collection in precious Bohemian crystal with metal fittings.

Spotkollektion aus wertvollem Bohemia-Kristall und verchromtem Metall.

Collection de petits spots en précieux cristal de Bohème et finitions en métal.

Colección de focos en precioso cristal de Bohemia y acabado en metal.

Коллекция вмонтированных ламп из ценного богемского хрусталя. Отделка из металла.

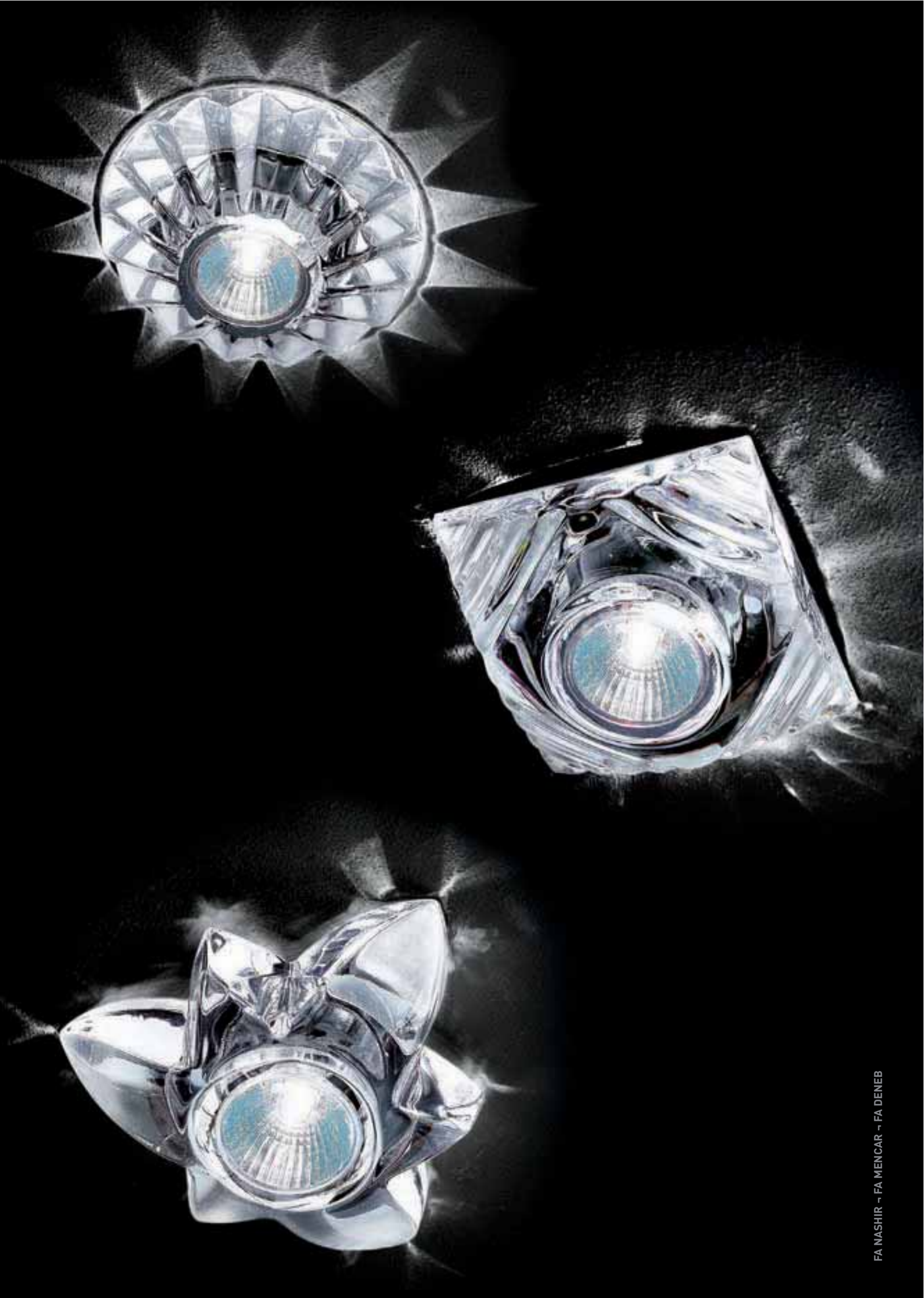



DESIGNERS

---

## DESIGNERS



### AION DESIGN

Aion is a group of designers that works in harness with Axo Light. For them design is like a game, a combination of shapes and thoughts, of objects and notions. Aion plays like a child creating the world, and in this endless game the items that come to life gain both a function and a story.

The world of objects is a complex universe where things not only serve a purpose but must also have a meaning for the people who buy and use them.

Objects, and in particular light fixtures, should express a specific creative process in their features, explain why they have a certain shape, give off or reflect a certain light.

The person who purchases these lamps should realize that they have a story to tell and that this is why they generate emotions, whether they illuminate a room or not.

The name of the lamp itself should tell about its project and its past. These are the main creative notions that Aion uses every time it designs a new item for Axo Light.

### DODO ARSLAN

Dodo Arslan worked with Alias, Arketipo, Axo Light, Guzzini, Joint Project, S.Pellegrino, Lucente, Saporiti, SpHaus, the glass artist Massimo Lunardon and the Dutch Embassy in Rome.

Dodo won Pirelli Pzero Competition and received various awards, such as: Young&Design, Mini Design and Art Directors Club. Recently he has been included in Taschen's book *Design Now*, world's 100 most important designers.

His projects have been displayed in many important exhibitions.

Dodo teaches at the Scuola Italiana di Design and at the Istituto Europeo di Design where he carried out workshops together with Ikea, Timberland, Chicco, Firme di Vetro and Vetrerie Bruni. Before founding his studio Dodo Arslan worked at Studio&Partners for Deutsche Post, British American Tobacco, Zumtobel Staff and won the Design Plus Prize. Dodo then joined Continuum where he worked for Motorola, Hewlett Packard, Elan, Voelkl, Samsung and won the Good Design Award and the KIDA Grand Prize.

### CANDIDO MAMMINI

Lo Studio snc owned by Letizia Mammini and Valeria Candido has its headquarters in Faenza, in an ancient villa of the 18th century immersed in nature, and has an international range of action.

Letizia Mammini was born in 1973 in Faenza. Since her degree thesis in industrial design her affinity with light has been coming out. Starting from 1996, she has been dealing with lighting: design and technical advice, design of illuminating bodies and fitting. She holds conferences about light in several universities and works as lighting designer for theatrical shows and other events.

Valeria Candido – same age, born in Pordenone, keen on visual art and creativity – got her school leaving in advertising graphics and photography and then got her degree in communication design. She has been dealing with graphics for big Italian companies for more than 10 years.

Lo Studio is the thought of the two promoting partners, attends to design, communication and lighting.

### MARCELLO FURLAN

Born in Murano, Venice, in 1962, Marcello Furlan owes his passion for blown glass to his father, a glassmaker master. In 1984 after studying architecture for several years at Venice University, he began to work in his family's glass business. During this period he was responsible for designing and developing new decorative glass features and objects. In 1998 he began a career as designer of lighting fixtures, in parallel with his other career as a freelance graphic artist in advertising. His research, which stems from the study of natural and organic elements, has reinterpreted the traditional, classic form of the Venetian chandelier in a contemporary vein, developing modern solutions that are increasingly free from convention. This is how he conceived Blum, an abundance of glass vases like sunrays burst out of a chrome-plated metal sphere, densely covering its surface to form a five-lobed flower that forms an impressive "blossom of crystal".



#### MICHAEL NEUMAYR

---

Versatile probably best describes Michael Morten Neumayr. In his designs he seeks a balanced fusion of his Danish-Austrian cultural background, his American design education, and his strong affinity for Asian philosophy, spirituality and culture. He believes that attractive design alone does not guarantee success. Design must take into account both "hard" facts like technical and cost limitations, and "soft" facts, like the feelings and emotions that get inspired by design. Neumayr has experienced many cultures during his travels, which visibly affect the products and environments that he designs. He also finds inspiration through the intense observation of the beauty of nature. Neumayr has won numerous competitions and awards and has been published in international design books, exhibitions, magazines. He also lectures in Europe and the U.S. about his unique approach on design, fusing European design heritage with American processes and Asian philosophy.



#### SANDRO SANTANTONIO

---

Sandro Santantonio Design boasts of an excellent knowledge in professional designing disciplines. The group represents a perfect syntheses in the various fields of contemporary design. From product design to domestic interiors or contract, from expositions to events, those are all arguments developed together with expertness, because all elements making up the Studio have distinguished experiences and tasks. The combinations of concept and technical knowledge is the fundament of their philosophy. Design Studio Sandro Santantonio has achieved various recognitions, such as the special mentioning at the Young Design award 2004 for the Flower chair, two special mentioning at the Young Design award 2005 for the sectional sofa Dune and the lamps collection Zoe, the special mentioning at the Young Design award in 2006 for the table Wave and the First Price at the competition for nautical design "Abitare il Mare 2006" by the Seatec-Carrara Fiere thanks to the project of a cruise ships luxury cabin.



#### MANUEL VIVIAN

---

Born in Venice in 1971, he received his diploma from the Istituto d'Arte di Venezia and from a relatively early age was greatly interested in design, above all that of blown glass, having been born and raised in a family of famous glass workers. His collaboration with Axo Light has become ever closer and more fruitful thanks to his sense of style, a style which has with great pace become entirely sympathetic to that of the company and has, in a short time, found itself devoted to a decorative eclecticism, sophistication and elegance, without however renouncing that touch of eccentricity. An eccentricity that can be found, for example, in his constant search for new and unusual materials to be used in the field of lighting design, a highly distinctive element of Manuel's work. Spanning nearly ten years, his collaboration with Axo Light continues to receive surprising plaudits and universal consent, both nationally and internationally, partly also thanks to the latest additions to the most popular Axo Light families.



# TECHNICAL DATA

---

226	ALEA
226	ARI
227	AURA
231	BALIOS
231	BALL UP
232	BLUM
233	BORA
234	CLARA
234	CLAVIUS
237	CRYSTAL SPOTLIGHT
238	ENTASIS
238	EXTREME
239	FALL IN LOVE
240	GLITTER
243	JAZZ
244	KALEIDOLIGHT
244	KORE
245	KOSHI
246	KROM
246	LEDGE
247	LOLLO
248	MARYLIN
249	MUSE
250	NELLY
251	PRIMULA
252	SHIRAZ
253	SLIGHT
254	SUBZERO

## ALEA

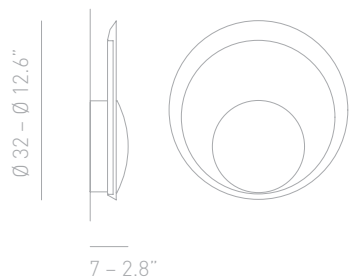

code **AP 36**  
 watt 2 x max 60 w  
 bulbs/ilcos HSGST/C/UB   
 socket 2 x G9  
 marks IP 20   

## ARI

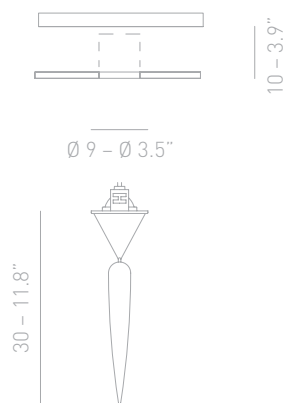

code **FA ARI P**  
 watt 1 x max 35 w  
 bulbs/ilcos HAGS/UB   
 socket 1 x GU 5.3  
 marks 12V  

 foro - hole  
 $\varnothing$  6.5 - 2.6"

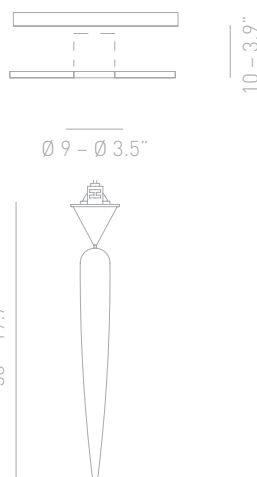

code **FA ARI G**  
 watt 1 x max 35 w  
 bulbs/ilcos HAGS/UB   
 socket 1 x GU 5.3  
 marks 12V  

 foro - hole  
 $\varnothing$  6.5 - 2.6"



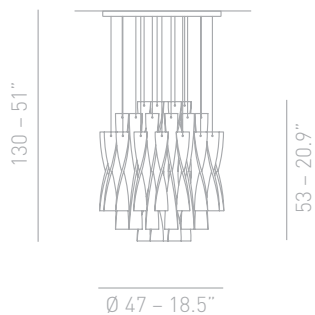

# AURA

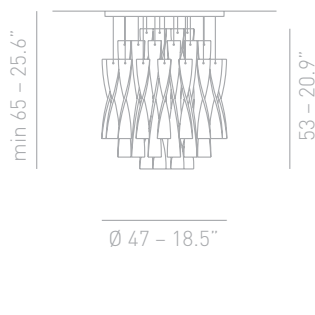

code **SP AURA 45**  
 watt 1 x max 150 w  
 bulbs/ilcos HSGST/C/UB   
 socket 1 x E27  
 marks   

rosone - canopy  
 Ø 48 - 18.9"  
 H 2.5 - 1"



code **PL AURA 45**  
 watt 1 x max 150 w  
 bulbs/ilcos HSGST/C/UB   
 socket 1 x E27  
 marks   

rosone - canopy  
 Ø 48 - 18.9"  
 H 2.5 - 1"

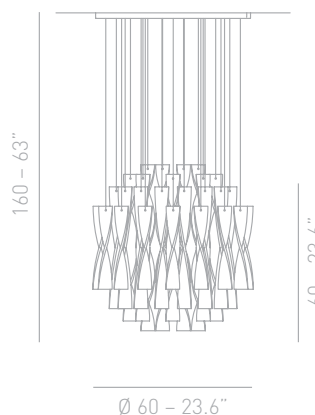

code **SP AURA 60**  
 watt 1 x max 250 w  
 bulbs/ilcos HSGST/C/UB   
 socket 1 x E27  
 marks   

rosone - canopy  
 Ø 60 - 23.6"  
 H 2.5 - 1"

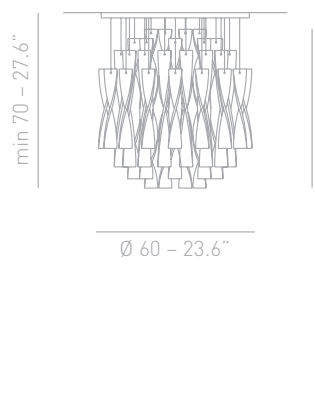

code **PL AURA 60**  
 watt 1 x max 250 w  
 bulbs/ilcos HSGST/C/UB   
 socket 1 x E27  
 marks   



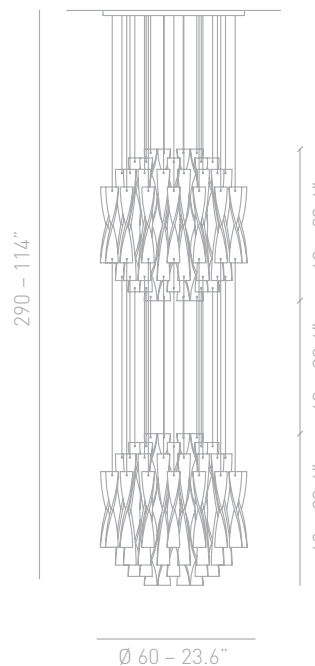

rosone - canopy  
 Ø 60 - 23.6"  
 H 2.5 - 1"

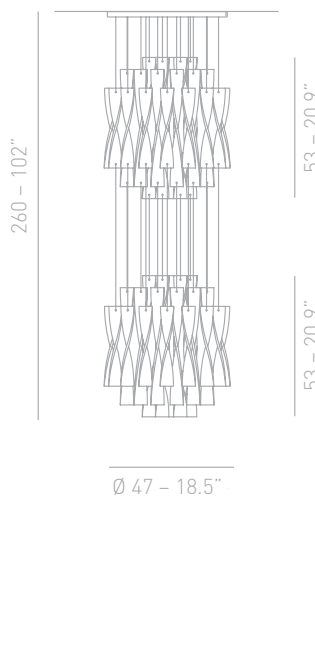

code **SP AU 60/2**  
 watt 2 x max 250 w  
 bulbs/ilcos HSGST/C/UB   
 socket 2 x E27  
 marks   

rosone - canopy  
 Ø 60 - 23.6"  
 H 2.5 - 1"



code **SP AU 45/2**  
 watt 2 x max 150 w  
 bulbs/ilcos HSGST/C/UB   
 socket 2 x E27  
 marks   

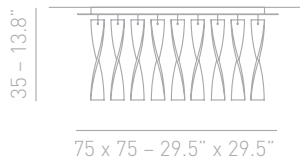

rosone - canopy  
 Ø 48 - 18.9"  
 H 2.5 - 1"

# AURA

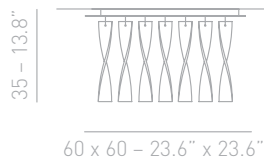

code **PL AUR G 30**  
 watt 4 x max 100 w  
 bulbs/ilcos HSGST/C/UB   
 socket 4 x E27  
 marks **CE**  



code **PL AUR P 30**  
 watt 4 x max 100 w  
 bulbs/ilcos HSGST/C/UB   
 socket 4 x E27  
 marks **CE**  

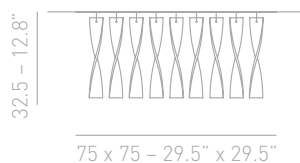

code **PL AU G 30 I**  
 watt 4 x max 100 w  
 bulbs/ilcos HSGST/C/UB   
 socket 4 x E27  
 marks **CE**  

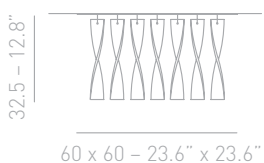

code **PL AU P 30 I**  
 watt 4 x max 100 w  
 bulbs/ilcos HSGST/C/UB   
 socket 4 x E27  
 marks **CE**  

 incasso - recessed  
 66 x 66 - 26" x 26"

profondità min - min depth  
 5 - 2"

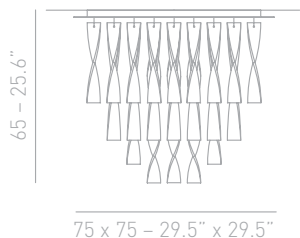

 incasso - recessed  
 56 x 56 - 22" x 22"

profondità min - min depth  
 5 - 2"

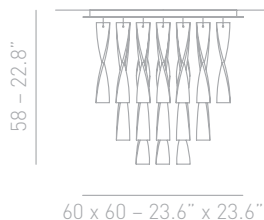

code **PL AURA GR**  
 watt 4 x max 100 w  
 bulbs/ilcos HSGST/C/UB   
 socket 4 x E27  
 marks **CE**  



code **PL AURA P**  
 watt 4 x max 100 w  
 bulbs/ilcos HSGST/C/UB   
 socket 4 x E27  
 marks **CE**  

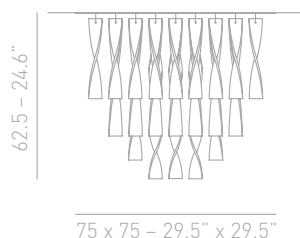

code **PL AURA G I**  
 watt 4 x max 100 w  
 bulbs/ilcos HSGST/C/UB   
 socket 4 x E27  
 marks **CE**  

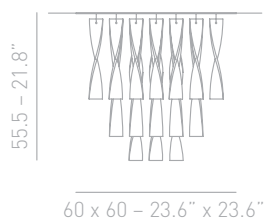

code **PL AURA P I**  
 watt 4 x max 100 w  
 bulbs/ilcos HSGST/C/UB   
 socket 4 x E27  
 marks **CE**  

 incasso - recessed  
 66 x 66 - 26" x 26"

profondità min - min depth  
 5 - 2"

 incasso - recessed  
 56 x 56 - 22" x 22"

profondità min - min depth  
 5 - 2"

# AURA

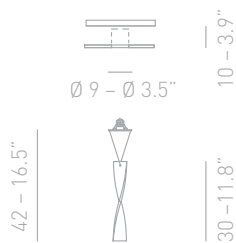

code **FA AURA 30**  
 watt 1 x max 35 w  
 bulbs/ilcos HAGS/UB   
 socket 1 x GU 5.3  
 marks 12V  

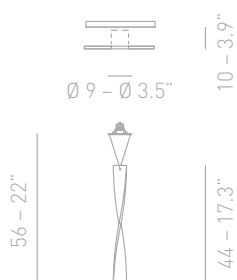

code **FA AURA 44**  
 watt 1 x max 35 w  
 bulbs/ilcos HAGS/UB   
 socket 1 x GU 5.3  
 marks 12V  

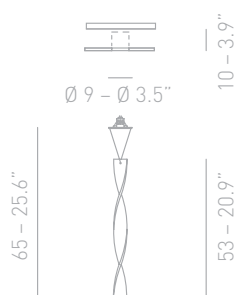
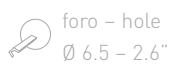



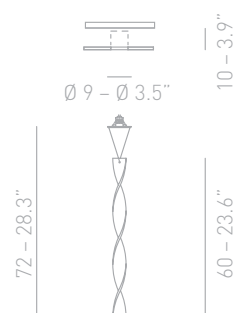

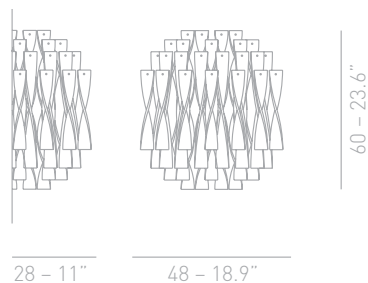
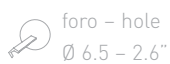

code **FA AURA 53**  
 watt 1 x max 35 w  
 bulbs/ilcos HAGS/UB   
 socket 1 x GU 5.3  
 marks 12V  



code **FA AURA 60**  
 watt 1 x max 35 w  
 bulbs/ilcos HAGS/UB   
 socket 1 x GU 5.3  
 marks 12V  



code **AP AURA**  
 watt 2 x max 100 w  
 bulbs/ilcos HSGST/C/UB   
 socket 2 x E27  
 marks   

watt 2 x max 100 w  
 bulbs/ilcos IAA/F   
 socket 2 x E27  
 marks   

# AURA

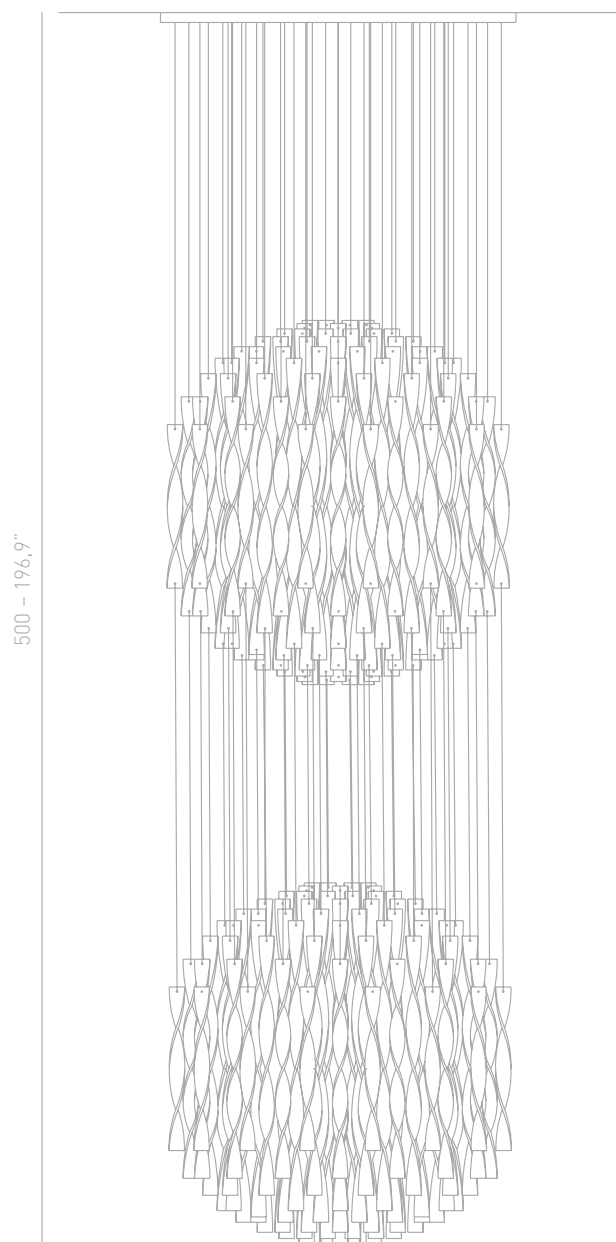

500 - 196,9"

Ø 140 - 55"

145 - 57"



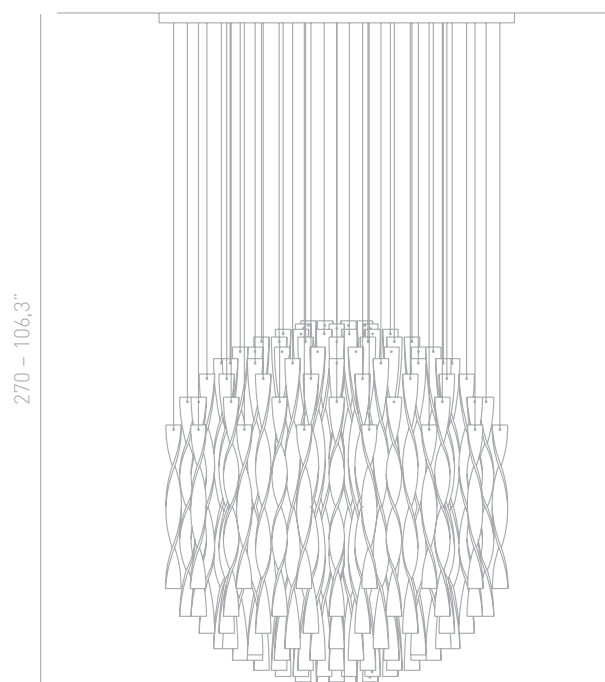

145 - 57"



270 - 106,3"

Ø 140 - 55"

140 - 55"

code **SP AUR 150**  
 watt 3 x max 250 w  
 bulbs/ilcos HSGST/C/UB   
 socket 3 x E27  
 marks   

code **SP A 150/2**  
 watt 6 x max 250 w  
 bulbs/ilcos HSGST/C/UB   
 socket 6 x E27  
 marks   

Progetto speciale sviluppato dall'Ufficio Tecnico Axo Light.  
 Custome project developed by Axo Light Technical Department.

## BALIOS

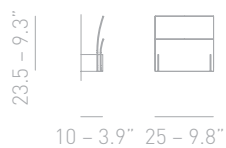

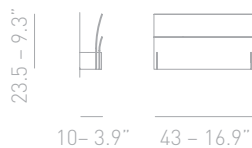

code **AP BALI 25**  
 watt 1 x max 100 w  
 bulbs/ilcos HDG (78)   
 socket 1 x R7s  
 marks **CE**  **ADA**

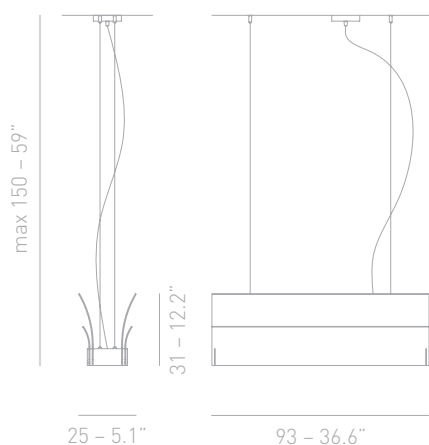

code **AP BALI 40**  
 watt 2 x max 60 w  
 bulbs/ilcos HDG (78)   
 socket 2 x R7s  
 marks **CE**  **ADA**

watt 1 x 24 w  
 bulbs/ilcos FSD   
 socket 1 x 2G11  
 marks **CE**  **ADA**



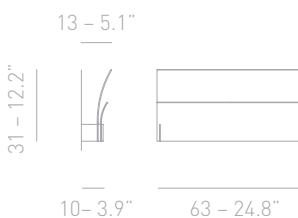

code **SP BALIOS**  
 watt 2 x max 39 w  
 bulbs/ilcos FDH   
 socket 2 x G5  
 marks **CE**  

rosone - canopy  
 Ø 12 - 4.7"  
 H 2.5 - 1"



code **AP BALI 60**  
 watt 3 x max 60 w  
 bulbs/ilcos HDG (78)   
 socket 3 x R7s  
 marks **CE** 

watt 2 x 24 w  
 bulbs/ilcos FDH   
 socket 2 x G5  
 marks **CE** 

## BALL UP

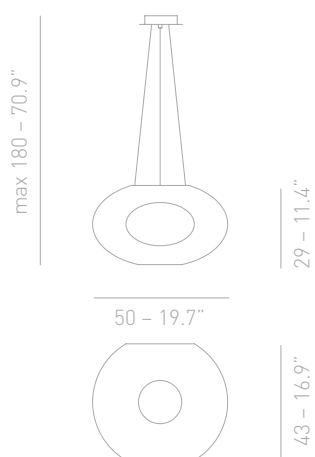

code **SP BALLUP**  
 watt 1 x max 200 w  
 bulbs/ilcos HDG (118)   
 socket 1 x R7s  
 marks **CE** 

rosone - canopy  
 Ø 12 - 4.7"  
 H 3 - 1.2"

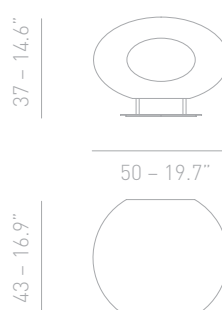

code **LT BALLUP**  
 watt 1 x max 150 w  
 bulbs/ilcos HDG (118)   
 socket 1 x R7s  
 marks **CE** 

## BALL UP

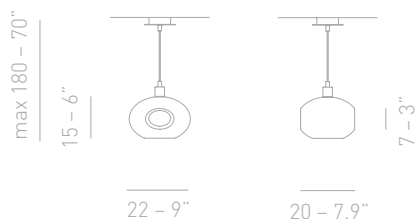

code **SP BALUP P**  
 watt 1 x max 40 w  
 bulbs/ilcos HSGST/C/UB   
 socket 1 x G9  
 marks **CE**  

rosone - canopy  
 Ø 12 - 4.7"  
 H 3 - 1.2"

## BLUM

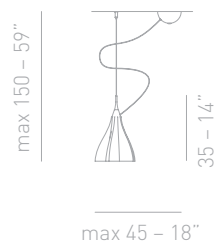

code **SP BLU DEC**  
 watt 1 x max 60 w  
 bulbs/ilcos IBP/C   
 socket 1 x E14  
 marks **CE**  

rosone - canopy  
 Ø 14 - 5.5"  
 H 7 - 2.8"

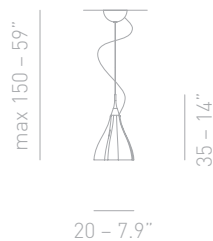

code **SP BLUM 1**  
 watt 1 x max 60 w  
 bulbs/ilcos IBP/C   
 socket 1 x E14  
 marks **CE**  



rosone - canopy  
 Ø 14 - 5.5"  
 H 7 - 2.8"

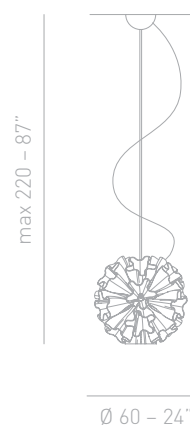

code **SP BLUM 31**  
 watt 31 x max 60 w  
 bulbs/ilcos IBP/C   
 socket 31 x E14  
 marks **CE**  

rosone - canopy  
 Ø 20 - 7.9"  
 H 10 - 3.9"



code **SP BLUM 19**  
 watt 19 x max 60 w  
 bulbs/ilcos IBP/C   
 socket 19 x E14  
 marks **CE**  

rosone - canopy  
 Ø 12 - 4.7"  
 H 6 - 2.4"

# BORA

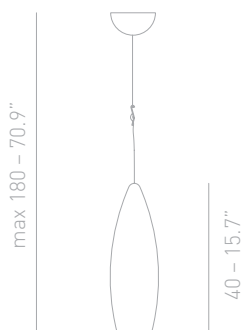

Ø 13 - 5.2"

code **SP 10**  
 watt 1 x max 100 w  
 bulbs/ilcos IAA/F   
 socket 1 x E27  
 marks IP40

watt 1 x max 23 w  
 bulbs/ilcos FBT   
 socket 1 x E27  
 marks IP40

only black colour

watt 1 x max 50 w  
 bulbs/ilcos HAGS/UB/30   
 socket 1 x E27  
 marks IP40

rosone - canopy

Ø 12 - 4.7"

H 6 - 2.4"

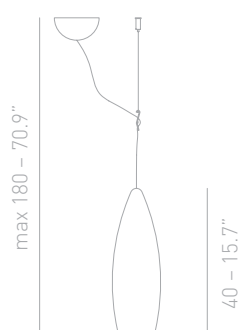

Ø 13 - 5.2"

code **SP 10 DEC**  
 watt 1/6 x max 100 w  
 bulbs/ilcos IAA/F   
 socket 1/6 x E27  
 marks IP40

watt 1/6 x max 23 w  
 bulbs/ilcos FBT   
 socket 1/6 x E27  
 marks IP40

only black colour

watt 1/6 x max 50 w  
 bulbs/ilcos HAGS/UB/30   
 socket 1/6 x E27  
 marks IP40

rosone - canopy

Ø 12 - 4.7"

H 6 - 2.4"



9 - 3.5" 13 - 5.1"

code **AP 10**  
 watt 1 x max 100 w  
 bulbs/ilcos IAA/F   
 socket 1 x E27  
 marks IP40 **ADA**

watt 1 x max 23 w  
 bulbs/ilcos FBT   
 socket 1 x E27  
 marks IP40 **ADA**

watt 1 x max 18 w  
 bulbs/ilcos FSQ   
 socket 1 x G24d-2  
 marks IP40 **ADA**

## CLARA

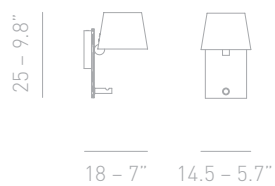

code **AP CLARA H**  
 watt 1 x max 40 w  
 bulbs/ilcos HSGST/C/UB   
 socket 1 x G9  
 marks **CE**  

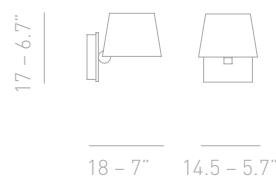

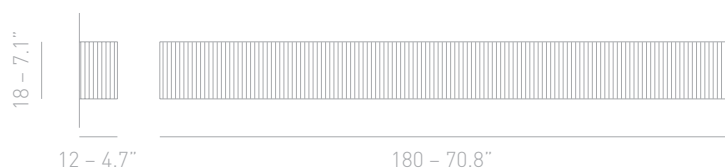

code **AP CLARA Q**  
 watt 1 x max 40 w  
 bulbs/ilcos HSGST/C/UB   
 socket 1 x G9  
 marks **CE**  

## CLAVIUS



code **AP CLAV GR**  
 watt 6 x max 60 w  
 bulbs/ilcos IBB/W   
 socket 6 x E14  
 marks **CE**  

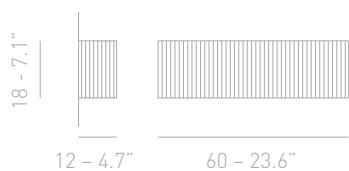

watt 2 x max 24 w  
 bulbs/ilcos FDH   
 socket 2 x G5  
 marks **CE**  

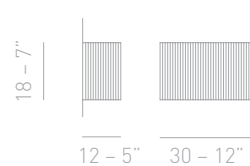

code **AP CLAV PI**  
 watt 2 x max 60 w  
 bulbs/ilcos IBB/W   
 socket 2 x E14  
 marks **CE**  

watt 1 x max 36 w  
 bulbs/ilcos FSD   
 socket 1 x 2G11  
 marks **CE**  



code **AP CLAV 30**  
 watt 1 x max 60 w  
 bulbs/ilcos IBB/W   
 socket 1 x E14  
 marks **CE**  

watt 1 x max 18 w  
 bulbs/ilcos FSQ   
 socket 1 x G24d-2  
 marks **CE**  

# CLAVIUS

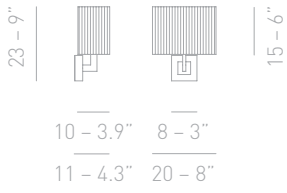

code **AP CLAV BR**  
 watt 1 x max 60 w  
 bulbs/ilcos IBB/W   
 socket 1 x E14  
 marks

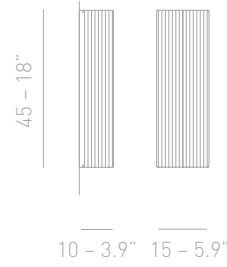

code **AP CLAV 45**  
 watt 2 x max 40 w  
 bulbs/ilcos IBB/W   
 socket 2 x E14  
 marks **ADA**

watt 2 x max 40 w  
 + 1 x max 25 w  
 bulbs/ilcos HGS/UB  
 + HSGST/C/UB  
 +   
 socket 2 x E14 halopar 16ALU  
 + 1 x G9  
 marks **ADA**

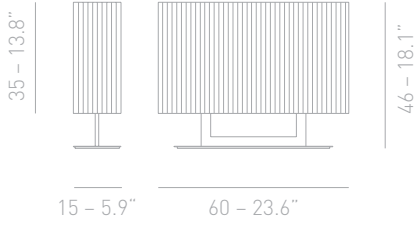

code **LT CLAVI G**  
 watt 2 x max 100 w  
 bulbs/ilcos IAA/F   
 socket 2 x E27  
 marks

watt 2 x max 18 w  
 bulbs/ilcos FSMH   
 socket 2 x GX24q-2  
 marks **ADA**

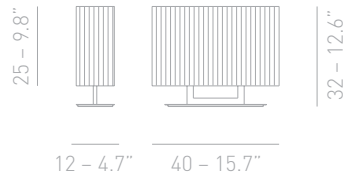

code **LT CLAVI P**  
 watt 2 x max 60 w  
 bulbs/ilcos IBB/W   
 socket 2 x E14  
 marks

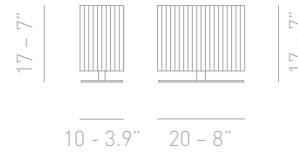

code **LT CLAV XP**  
 watt 1 x max 60 w  
 bulbs/ilcos IBB/W   
 socket 1 x E14  
 marks

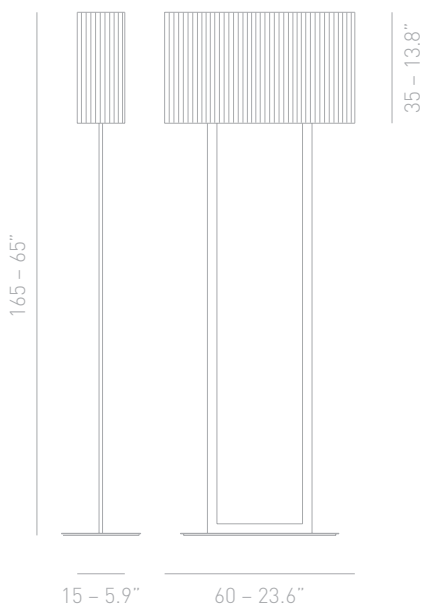

code **PT CLAVIU**  
 watt 2 x max 100 w  
 bulbs/ilcos IAA/F   
 socket 2 x E27  
 marks

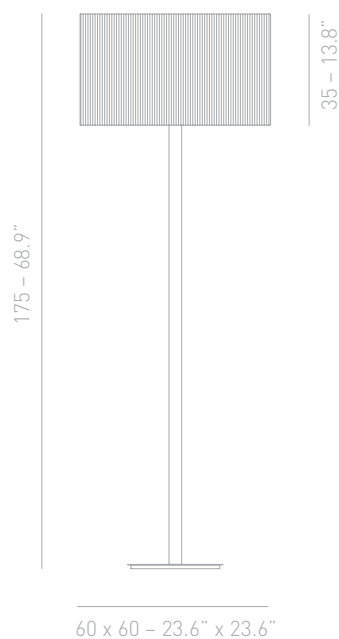

code **PT CLAV 60**  
 watt 4 x max 100 w  
 bulbs/ilcos IAA/F   
 socket 4 x E27  
 marks

# CLAVIUS

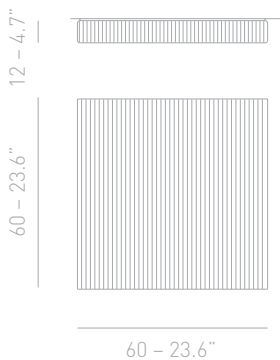

code **PL CLAVIU**  
 watt 3 x max 60 w  
 bulbs/ilcos IAA/F   
 socket 3 x E27  
 marks

watt 1 x max 55 w  
 bulbs/ilcos FSC   
 socket 1 x 2GX13  
 marks

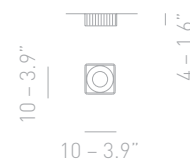

code **FA CLAVIU**  
 watt 1 x max 35 w  
 bulbs/ilcos HAGS/UB   
 socket 1 x GU 5.3  
 marks 12V

foro - hole  
 $\varnothing$  6.5 - 2.6"

profondità min - min depth  
 10 - 3.9"

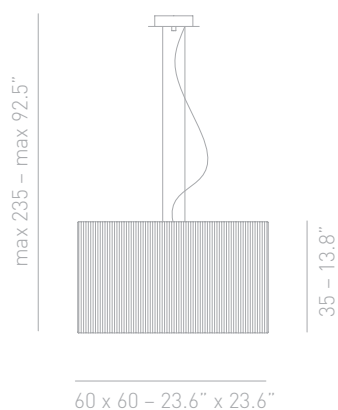

code **SP CLAV 60**  
 watt 4 x max 100 w  
 bulbs/ilcos IAA/F   
 socket 4 x E27  
 marks

rosone - canopy  
 $\varnothing$  16 - 6.3"  
 H 4 - 1.6"

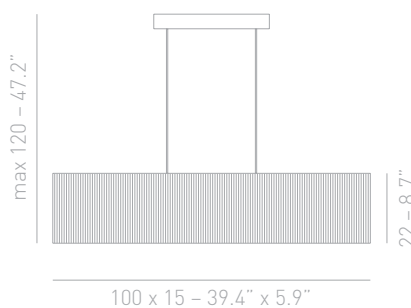

code **SP CLAVIU**  
 watt 3 x max 100 w  
 bulbs/ilcos IAA/F   
 socket 3 x E27  
 marks

rosone - canopy  
 32 x 11 x H 3  
 12.6" x 4.3" x H 1.2"

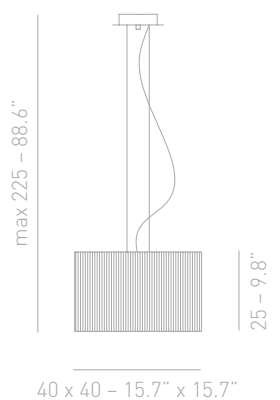

code **SP CLAV 40**  
 watt 4 x max 60 w  
 bulbs/ilcos IAA/F   
 socket 4 x E27  
 marks

rosone - canopy  
 $\varnothing$  16 - 6.3"  
 H 4 - 1.6"

watt 1 x max 39 w  
 bulbs/ilcos FDH   
 socket 1 x G5  
 marks

rosone - canopy  
 36.5 x 11 x H 4.6  
 14.4" x 4.3" x H 1.8"

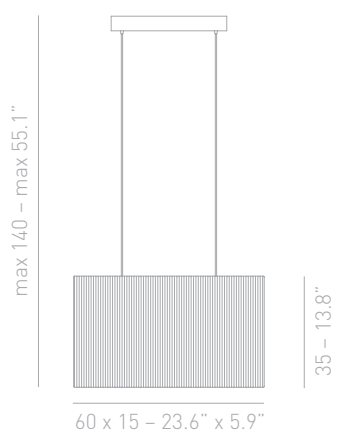

code **SP CLAVI P**  
 watt 2 x max 100 w  
 bulbs/ilcos IAA/F   
 socket 2 x E27  
 marks

rosone - canopy  
 35 x 11 x H 4  
 13.8" x 4.3" x H 1.6"

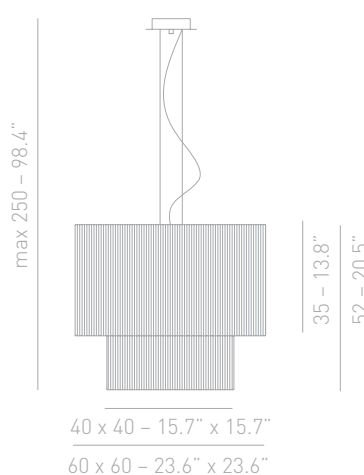

code **SP CL 60 40**  
 watt 4 x max 100 w  
 bulbs/ilcos IAA/F   
 socket 4 x E27  
 marks

rosone - canopy  
 $\varnothing$  16 - 6.3"  
 H 4 - 1.6"

# CRYSTAL SPOTLIGHT

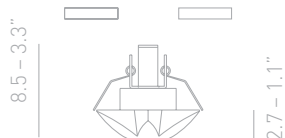

Ø 11 - 4.3"



foro - hole  
Ø 5.5 - 2.2"

profondità min - min depth  
10 - 3.9"

code **FA DENEBO**  
watt 1 x max 40 w  
bulbs/ilcos HSGST/C/UB   
socket 1 x G9  
marks **CE**   

watt 1 x max 35 w  
bulbs/ilcos HSGST/UB/IB   
socket 1 x GY 6.35  
marks 12V **CE**   

watt 1 x max 35 w  
bulbs/ilcos HRGS/UB   
socket 1 x GU 4  
marks 12V **CE**   

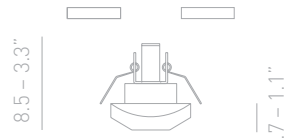

8 - 3.1"



foro - hole  
Ø 5.5 - 2.2"

profondità min - min depth  
10 - 3.9"

code **FA MENCAR**  
watt 1 x max 40 w  
bulbs/ilcos HSGST/C/UB   
socket 1 x G9  
marks **CE**   

watt 1 x max 35 w  
bulbs/ilcos HSGST/UB/IB   
socket 1 x GY 6.35  
marks 12V **CE**   

watt 1 x max 35 w  
bulbs/ilcos HRGS/UB   
socket 1 x GU 4  
marks 12V **CE**   

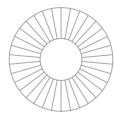
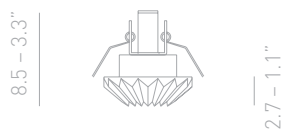

Ø 9.5 - 3.7"



foro - hole  
Ø 5.5 - 2.2"

profondità min - min depth  
10 - 3.9"

code **FA NASHIR**  
watt 1 x max 40 w  
bulbs/ilcos HSGST/C/UB   
socket 1 x G9  
marks **CE**   

watt 1 x max 35 w  
bulbs/ilcos HSGST/UB/IB   
socket 1 x GY 6.35  
marks 12V **CE**   

watt 1 x max 35 w  
bulbs/ilcos HRGS/UB   
socket 1 x GU 4  
marks 12V **CE**   

## ENTASIS

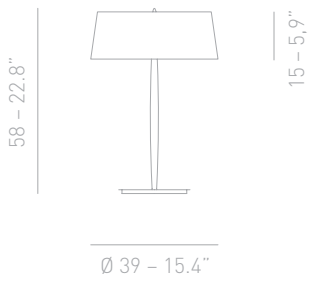

code **LT ENTASI**  
 watt 3 x max 40 w  
 bulbs/ilcos IBB/W   
 socket 3 x E14  
 marks

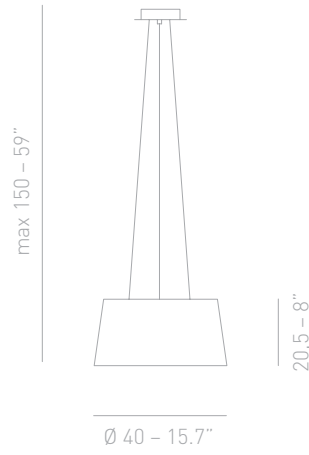

code **SP ENTASI**  
 watt 1 x max 100 w  
 bulbs/ilcos IAA/F   
 socket 1 x E27  
 marks

rosone - canopy  
 Ø 16 - 6.3"  
 H 3 - 1.2"



code **PT ENTASI**  
 watt 3 x max 60 w  
 bulbs/ilcos IBB/W   
 socket 3 x E14  
 marks

## EXTREME



code **AP EXTR 60 CS**  
 watt 2 x max 100 w  
 bulbs/ilcos HDG (118)   
 socket 2 x R7s  
 marks

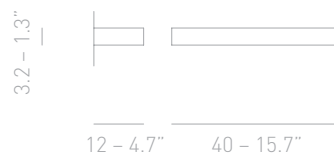

code **AP EXTR 40 CS**  
 watt 1 x max 100 w  
 bulbs/ilcos HDG (118)   
 socket 1 x R7s  
 marks

## EXTREME



code **AP EXTR 60 PI**  
 watt 2 x max 150 w  
 bulbs/ilcos HDG (118)   
 socket 2 x R7s  
 marks    

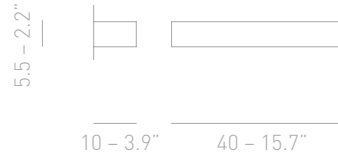

code **AP EXTR 40 PI**  
 watt 1 x max 200 w  
 bulbs/ilcos HDG (118)   
 socket 1 x R7s  
 marks    

## FALL IN LOVE

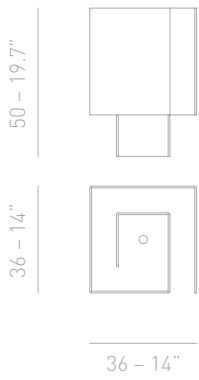

code **LT FALLIN**  
 watt 1 x max 150 w  
 bulbs/ilcos IAA/F   
 socket 1 x E27  
 marks    

# GLITTER

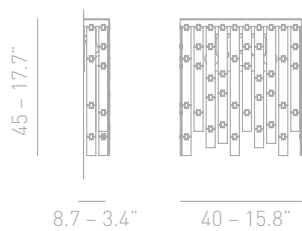

code **AP GLITT C**  
 watt 3 x max 60 w  
 bulbs/ilcos IBP/C   
 socket 3 x E14  
 marks **CE** **ADA**

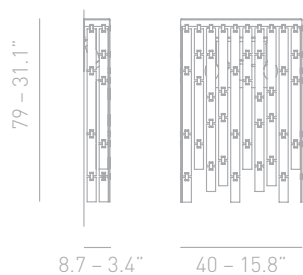

code **AP GLITT L**  
 watt 3 x max 60 w  
 bulbs/ilcos IBP/C   
 socket 3 x E14  
 marks **CE** **ADA**

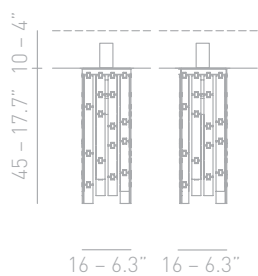

code **FA GLITTE**  
 watt 1 x max 100 w  
 bulbs/ilcos IAA/C   
 socket 1 x E27  
 marks **CE**

watt 1 x max 20 w  
 bulbs/ilcos FBA   
 socket 1 x E27  
 marks **CE**

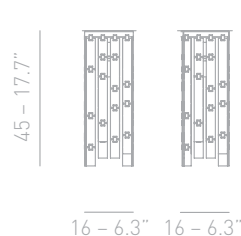

code **PL GLIT 16**  
 watt 1 x max 100 w  
 bulbs/ilcos IAA/C   
 socket 1 x E27  
 marks **CE**

watt 1 x max 20 w  
 bulbs/ilcos FBA   
 socket 1 x E27  
 marks **CE**

foro - hole  
 Ø 5 - 2"

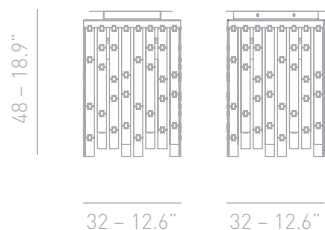

code **PL GLI 32 C**  
 watt 4 x max 100 w  
 bulbs/ilcos IAA/C   
 socket 4 x E27  
 marks **CE**

watt 4 x max 20 w  
 bulbs/ilcos FBA   
 socket 4 x E27  
 marks **CE**

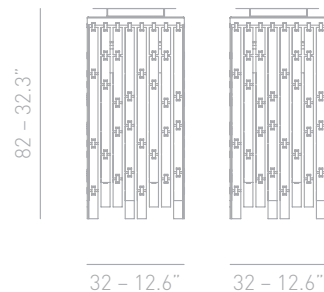

code **PL GLI 32 L**  
 watt 4 x max 100 w  
 bulbs/ilcos IAA/C   
 socket 4 x E27  
 marks **CE**

watt 4 x max 20 w  
 bulbs/ilcos FBA   
 socket 4 x E27  
 marks **CE**

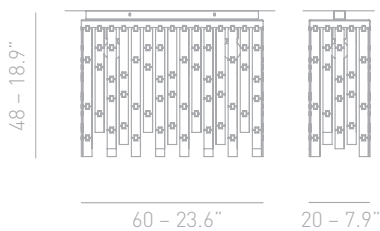

code **PL GLI 60 C**  
 watt 2 x max 100 w  
 bulbs/ilcos IAA/C   
 socket 2 x E27  
 marks **CE**

watt 2 x max 20 w  
 bulbs/ilcos FBA   
 socket 2 x E27  
 marks **CE**

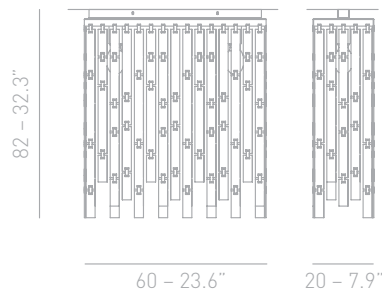

code **PL GLI 60 L**  
 watt 2 x max 100 w  
 bulbs/ilcos IAA/C   
 socket 2 x E27  
 marks **CE**

watt 2 x max 20 w  
 bulbs/ilcos FBA   
 socket 2 x E27  
 marks **CE**

# GLITTER

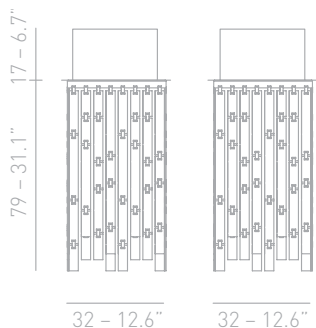

code **PL GL 32 L I**  
 watt 4 x max 50 w  
 bulbs/ilcos HMGS/UB   
 socket 4 x G53  
 marks 12V

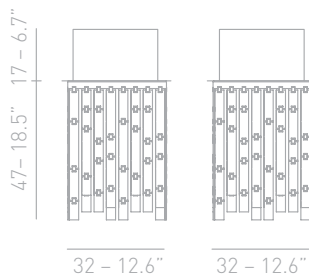

code **PL GL 32 C I**  
 watt 4 x max 50 w  
 bulbs/ilcos HMGS/UB   
 socket 4 x G53  
 marks 12V

foro - hole  
 29.5 x 29.5 - 11.6" x 11.6"

foro - hole  
 29.5 x 29.5 - 11.6" x 11.6"

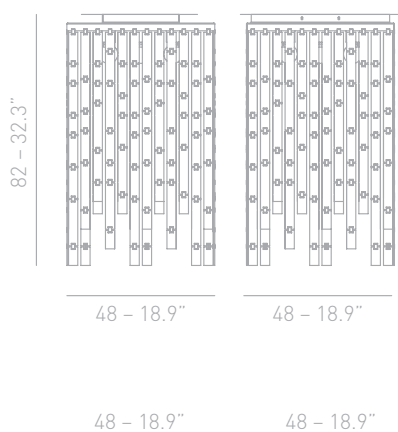

code **PL GLI 48 L**  
 watt 5 x max 100 w  
 bulbs/ilcos IAA/C   
 socket 5 x E27  
 marks

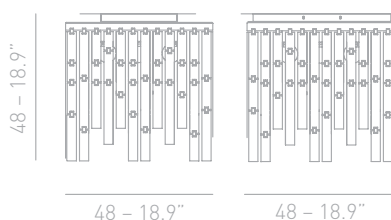

code **PL GLI 48 C**  
 watt 5 x max 100 w  
 bulbs/ilcos IAA/C   
 socket 5 x E27  
 marks

watt 5 x max 20 w  
 bulbs/ilcos FBA   
 socket 5 x E27  
 marks

watt 5 x max 20 w  
 bulbs/ilcos FBA   
 socket 5 x E27  
 marks

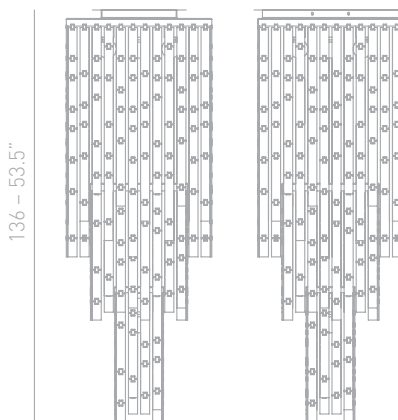

code **PL GLI 48 3**  
 watt 5 x max 100 w  
 bulbs/ilcos IAA/C   
 socket 5 x E27  
 marks

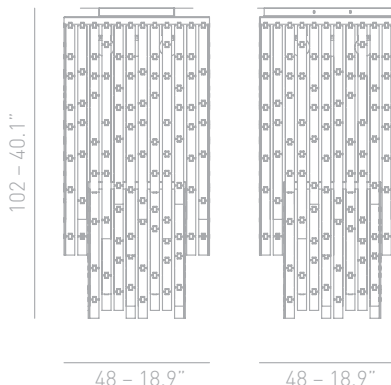

code **PL GLI 48 2**  
 watt 5 x max 100 w  
 bulbs/ilcos IAA/C   
 socket 5 x E27  
 marks

watt 5 x max 20 w  
 bulbs/ilcos FBA   
 socket 5 x E27  
 marks

watt 5 x max 20 w  
 bulbs/ilcos FBA   
 socket 5 x E27  
 marks

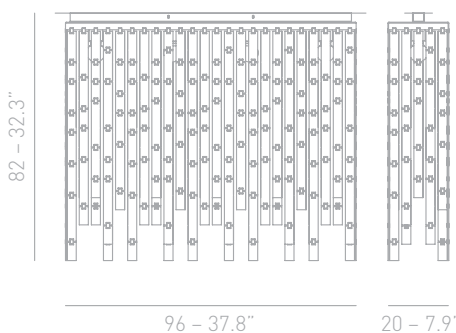

code **PL GLIT 96**  
 watt 4 x max 100 w  
 bulbs/ilcos IAA/C   
 socket 4 x E27  
 marks

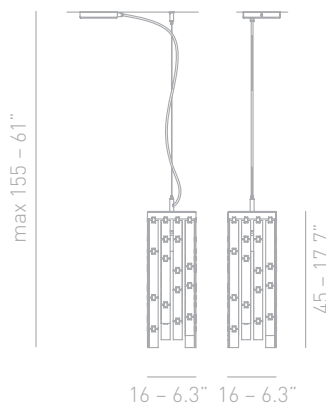

code **SP GLIT 16**  
 watt 1 x max 100 w  
 bulbs/ilcos IAA/C   
 socket 1 x E27  
 marks

watt 4 x max 20 w  
 bulbs/ilcos FBA   
 socket 4 x E27  
 marks

watt 1 x max 20 w  
 bulbs/ilcos FBA   
 socket 1 x E27  
 marks

rosone - canopy  
 12.4 x 12.4 x H 2  
 4.9" x 4.9" x H 0.8"

# GLITTER

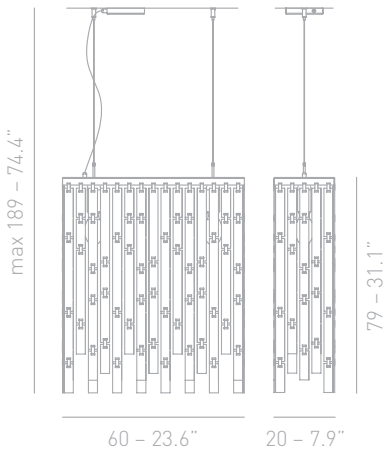

code **SP GLI 60 L**  
 watt 2 x max 100 w  
 bulbs/ilcos IAA/C   
 socket 2 x E27  
 marks

watt 2 x max 20 w  
 bulbs/ilcos FBA   
 socket 2 x E27  
 marks

rosone - canopy  
 12.4 x 12.4 x H 2  
 4.9" x 4.9" x H 0.8"

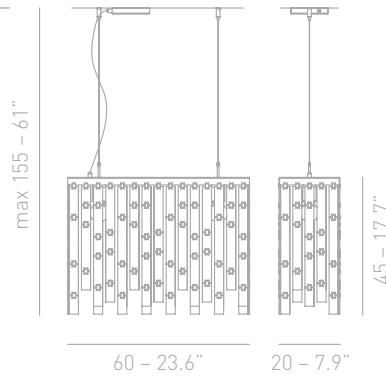

code **SP GLI 60 C**  
 watt 2 x max 100 w  
 bulbs/ilcos IAA/C   
 socket 2 x E27  
 marks

watt 2 x max 20 w  
 bulbs/ilcos FBA   
 socket 2 x E27  
 marks

rosone - canopy  
 12.4 x 12.4 x H 2  
 4.9" x 4.9" x H 0.8"

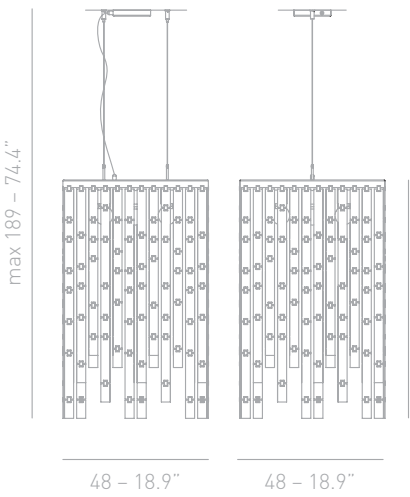

code **SP GLI 48 L**  
 watt 5 x max 100 w  
 bulbs/ilcos IAA/C   
 socket 5 x E27  
 marks

watt 5 x max 20 w  
 bulbs/ilcos FBA   
 socket 5 x E27  
 marks

rosone - canopy  
 12.4 x 12.4 x H 2  
 4.9" x 4.9" x H 0.8"

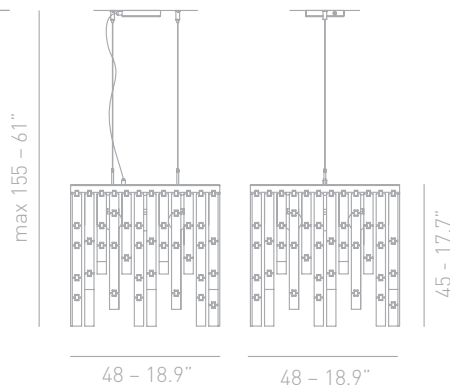

code **SP GLI 48 C**  
 watt 5 x max 100 w  
 bulbs/ilcos IAA/C   
 socket 5 x E27  
 marks

watt 5 x max 20 w  
 bulbs/ilcos FBA   
 socket 5 x E27  
 marks

rosone - canopy  
 12.4 x 12.4 x H 2  
 4.9" x 4.9" x H 0.8"

# GLITTER

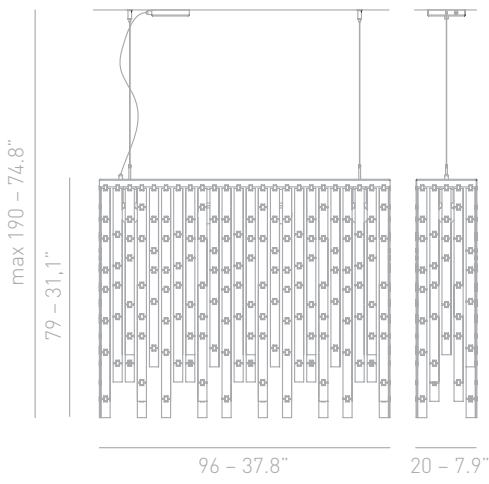

code **SP GLIT 96**  
 watt 4 x max 100 w  
 bulbs/ilcos IAA/C   
 socket 4 x E27  
 marks

watt 4 x max 20 w  
 bulbs/ilcos FBA   
 socket 4 x E27  
 marks

rosone - canopy  
 12.4 x 12.4 x H 2  
 4.9" x 4.9" x H 0.8"

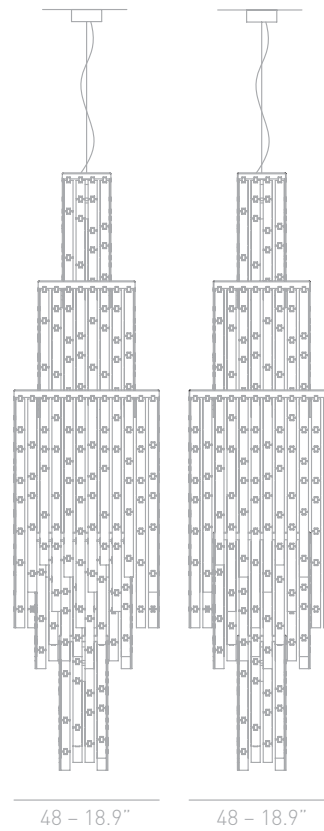

code **SP GLITT G**  
 watt 13 x max 100 w  
 + 4 x max 25 w  
 bulbs/ilcos IAA/C + IBP/C  
 +   
 socket 13 x E27  
 + 4 x E14  
 marks

rosone - canopy  
 17.5 x 17.5 x H 3  
 6.9" x 6.9" x H 1.2"

# JAZZ

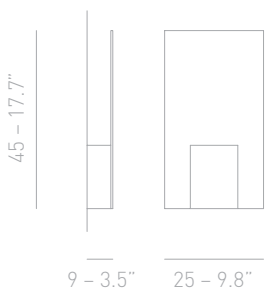



code **AP JAZZ**  
 watt 2 x max 60 w  
 bulbs/ilcos IBB/W   
 socket 2 x E14  
 marks **ADA**

watt 2 x max 18  
 bulbs/ilcos FSQ   
 socket 2 x G24d-2  
 marks **ADA**

watt 2 x max 18 elektr  
 bulbs/ilcos FSQ   
 socket 2 x G24q-2  
 marks **ADA**

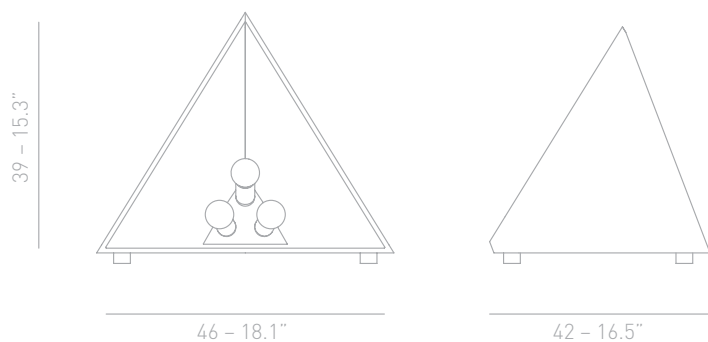



## KALEIDOLIGHT



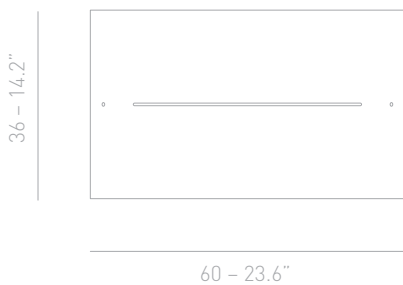



code **LT KALEID**  
 watt 3 x max 7 w  
 bulbs/ilcos FB   
 socket 3 x E14 fluo  
 marks   

## KORE





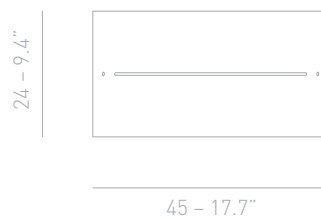

code **AP KORE 60**  
 watt 1 x max 200 w  
 bulbs/ilcos HDG (118)   
 socket 1 x R7s  
 marks   

watt 2 x max 24 w  
 bulbs/ilcos HDG (118)   
 socket 2 x 2G11  
 marks   

profondità - depth  
 10 - 3.9"



code **AP KORE 40**  
 watt 1 x max 150 w  
 bulbs/ilcos HDG (118)   
 socket 1 x R7s  
 marks   

watt 1 x max 18 w  
 bulbs/ilcos FSMH   
 socket 1 x GX24q-2  
 marks   

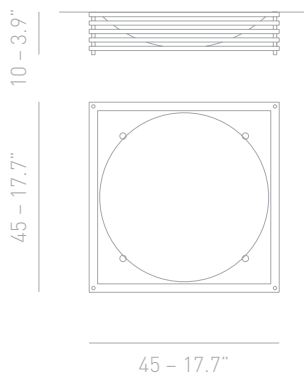

profondità - depth  
 10 - 3.9"

# KOSHI

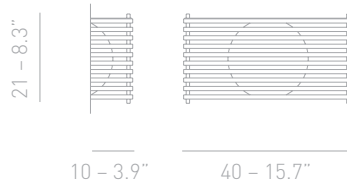

code **PL KOSHI**  
 watt 1 x max 150 w  
 bulbs/ilcos HDG (118)   
 socket 1 x R7s  
 marks **CE**  



code **AP KOSHI**  
 watt 1 x max 100 w  
 bulbs/ilcos HDG (78)   
 socket 1 x R7s  
 marks **CE**   **ADA**

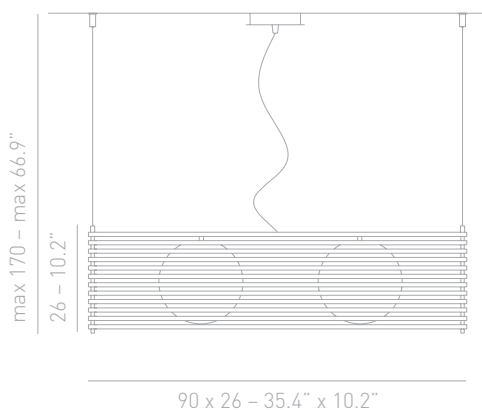

code **SP KOSHI G**  
 watt 2 x max 100 w  
 bulbs/ilcos HSGST/C/UB   
 socket 2 x E27  
 marks **CE**  

rosone - canopy  
 Ø 11.7 - 4.6"  
 H 2.4 - 0.9"

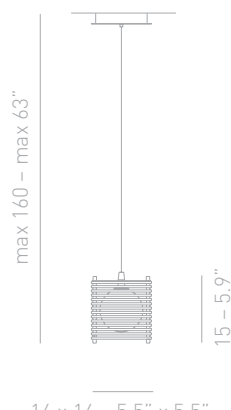

code **SP KOSHI P**  
 watt 1 x max 40 w  
 bulbs/ilcos HSGST/C/UB   
 socket 1 x G9  
 marks **CE**  

rosone - canopy  
 14 x 14 x H 2.5  
 5.5" x 5.5" x H 1"

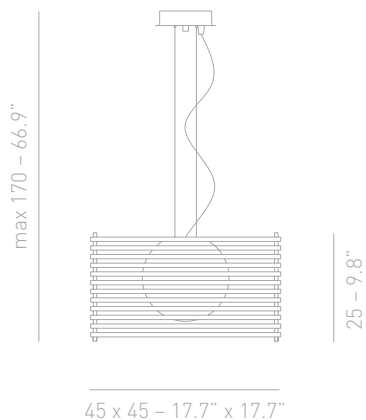

code **SP KOSHI M**  
 watt 1 x max 100 w  
 bulbs/ilcos HSGST/C/UB   
 socket 1 x E27  
 marks **CE**  

rosone - canopy  
 16 x 16 x H 3  
 6.3" x 6.3" x H 1.2"

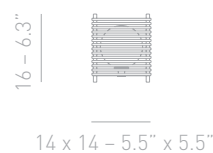

code **LT KOSHI P**  
 watt 1 x max 40 w  
 bulbs/ilcos HSGST/C/UB   
 socket 1 x G9  
 marks **CE**  

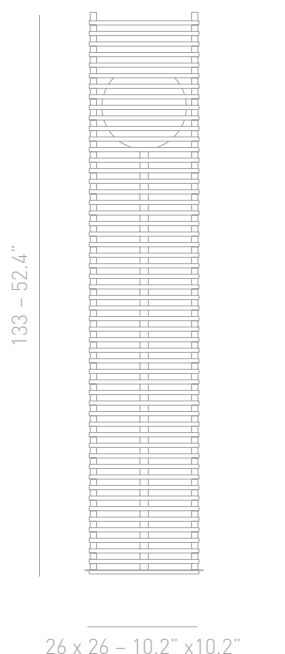



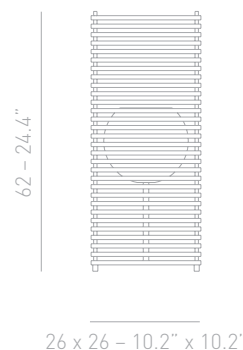



code **PT KOSHI**  
 watt 1 x max 150 w  
 bulbs/ilcos HSGST/C/UB   
 socket 1 x E27  
 marks **CE**   

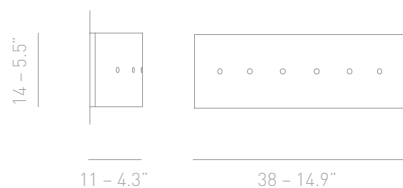

code **LT KOSHI G**  
 watt 1 x max 100 w  
 bulbs/ilcos HSGST/C/UB   
 socket 1 x E27  
 marks **CE**   





## KROM



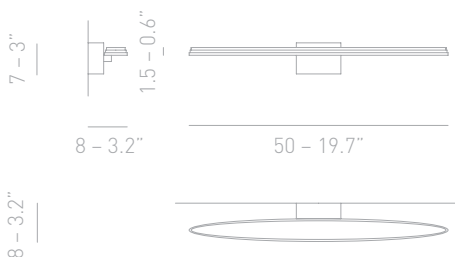



code **AP KROM**  
 watt 1 x max 150 w  
 bulbs/ilcos HDG (78)   
 socket 1 x R7s  
 marks    

## LEDGE

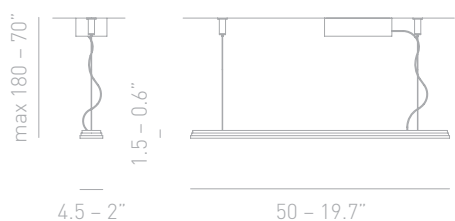





code **AP LEDGE**  
 watt 1 x max 12 w  
 bulbs/ilcos hp linear led module  
 marks    

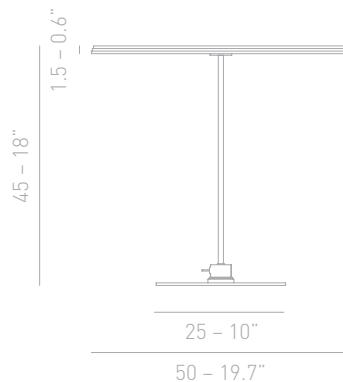

code **SP LEDGE**  
 watt 1 x max 12 w  
 bulbs/ilcos hp linear led module  
 marks    

rosone - canopy  
 14 x 70 x H 3.5  
 5.5" x 27.6" x H 1.4"



code **LT LEDGE**  
 watt 1 x max 12 w  
 bulbs/ilcos hp linear led module  
 marks    

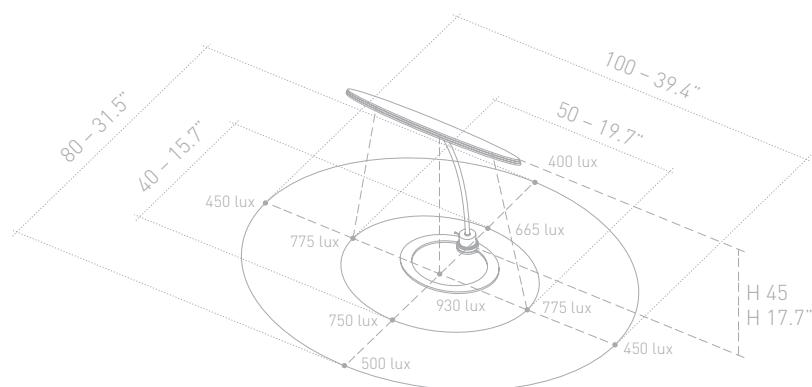

### LT LEDGE

valori di illuminamento - illuminance value

Temperatura di colore - 5400 K (disponibile anche a 3200 K)

Colour temperature - 5400 K (available also 3200 K)

Valori riferiti ad un illuminamento medio di 300 lux

Measures referred to an average illuminance value of 300 lux

# LOLLO

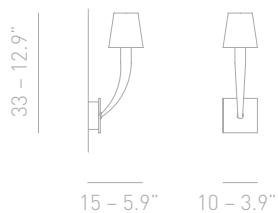

code **AP LOLLO 1 B**  
 watt 1 x max 40 w  
 bulbs/ilcos IBB/W   
 socket 1 x E14  
 marks

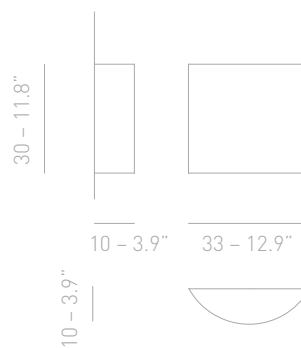

code **AP LOLLO**  
 watt 1 x max 100 w  
 bulbs/ilcos IAA/F   
 socket 1 x E27  
 marks **ADA**

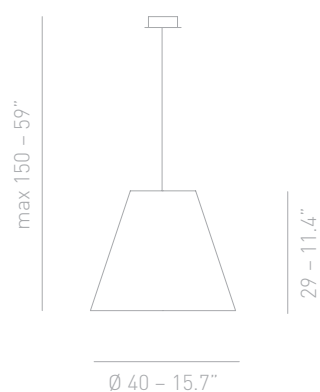

code **SP LOLLO**  
 watt 1 x max 100 w  
 bulbs/ilcos IAA/F   
 socket 1 x E27  
 marks



rosone - canopy  
 Ø 12 - 4.7"  
 H 6 - 2.4"

code **LT LOLLO P**  
 watt 1 x max 40 w  
 bulbs/ilcos IBB/W   
 socket 1 x E14  
 marks

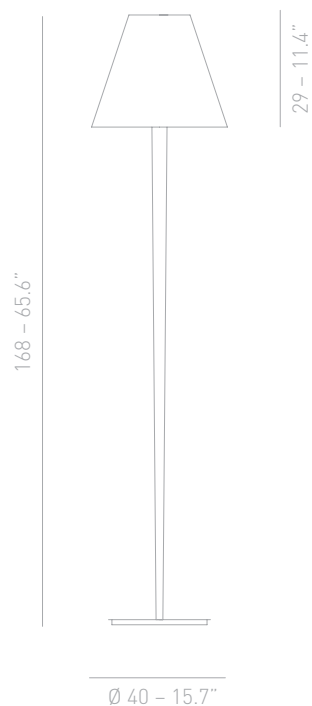

code **PT LOLLO**  
 watt 2 x max 100 w  
 bulbs/ilcos IAA/F   
 socket 2 x E27  
 marks

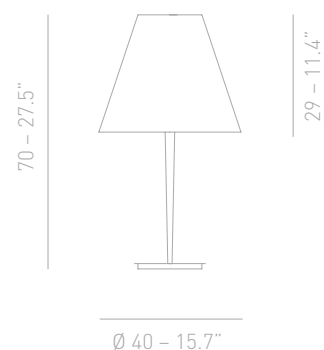

code **LT LOLLO G**  
 watt 2 x max 100 w  
 bulbs/ilcos IAA/F   
 socket 2 x E27  
 marks

# MARYLIN

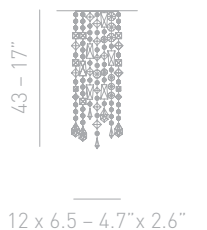

code **FA MARYLI**  
 watt 1 x max 35 w  
 bulbs/ilcos HAGS/UB   
 socket 1 x GU 5.3  
 marks 12V

foro - hole  
 Ø 6.5 - 2.6"

profondità min - min depth  
 10 - 3.9"

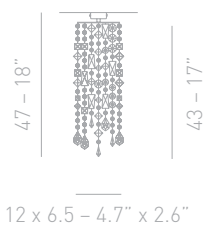

code **PL MARY 12**  
 watt 1 x max 60 w  
 bulbs/ilcos HSGST/C/UB   
 socket 1 x G9  
 marks



code **AP MARYLI**  
 watt 1 x max 60 w  
 bulbs/ilcos IAA/C   
 socket 1 x E27  
 marks

profondità - depth  
 10 - 3.9"

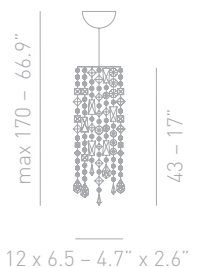

code **SP MARYL P**  
 watt 1 x max 40 w  
 bulbs/ilcos HSGST/C/UB   
 socket 1 x G9  
 marks

rosone - canopy  
 Ø 12 - 4.7"  
 H 6 - 2.4"

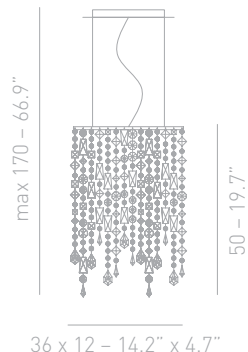

code **SP MARY 36**  
 watt 1 x max 60 w  
 bulbs/ilcos HSGST/C/UB   
 socket 1 x G9  
 marks

rosone - canopy  
 30.5 x 10.5 x H 3.2  
 12" x 4.1" x H 1.3"

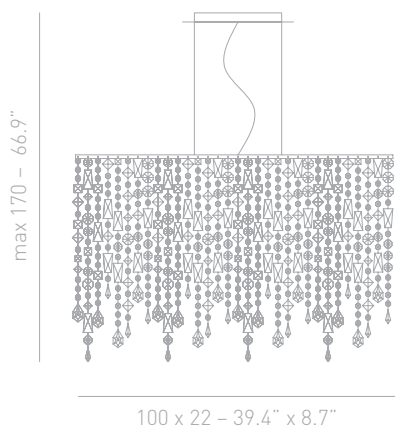

code **SP MAR 100**  
 watt 6 x max 60 w  
 bulbs/ilcos HSGST/C/UB   
 socket 6 x G9  
 marks

rosone - canopy  
 30.5 x 10.5 x H 3.2  
 12" x 4.1" x H 1.3"

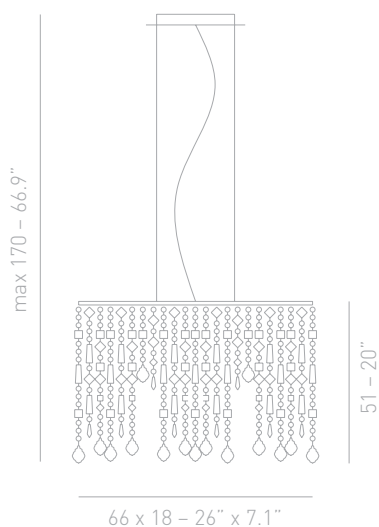

code **SP MARYLI**  
 watt 4 x max 60 w  
 bulbs/ilcos HSGST/C/UB   
 socket 4 x G9  
 marks

rosone - canopy  
 30.5 x 10.5 x H 3.2  
 12" x 4.1" x H 1.3"

# MARYLIN

36 x 12 - 14.2" x 4.7"

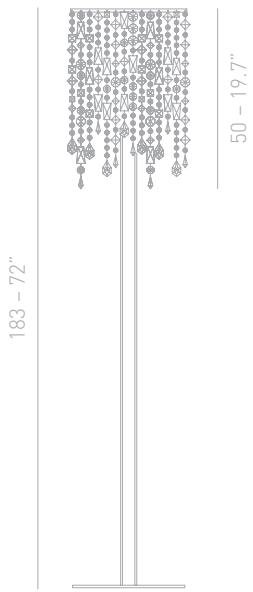

32 x 36 - 12.6" x 14.2"

code **PT MARYLI**  
 watt 1 x max 150 w  
 bulbs/ilcos IAA/C   
 socket 1 x E27  
 marks

# MUSE

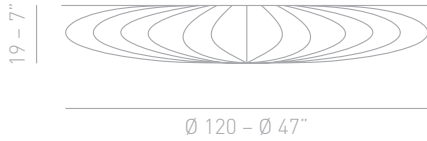

code **PL MUS 120**  
 watt 3 x max 100 w  
 bulbs/ilcos IAA/W   
 socket 3 x E27  
 marks

watt 1 x max 55 w  
 bulbs/ilcos FSC   
 socket 1 x 2GX13  
 marks

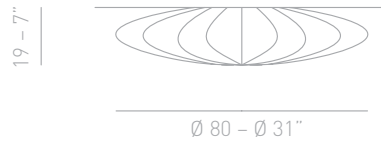

code **PL MUSE 80**  
 watt 3 x max 100 w  
 bulbs/ilcos IAA/W   
 socket 3 x E27  
 marks

watt 1 x max 55 w  
 bulbs/ilcos FSC   
 socket 1 x 2GX13  
 marks

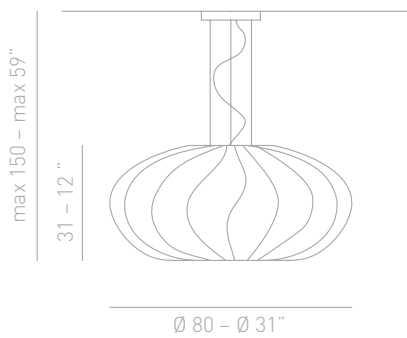

code **SP MUSE**  
 watt 1 x max 150 w  
 bulbs/ilcos IAG/WP   
 socket 1 x E27 globe  
 marks

watt 1 x max 21 w  
 bulbs/ilcos FBT   
 socket 1 x E27  
 marks

rosone - canopy  
 Ø 21.6 - 8.5"  
 H 3 - 1.2"

# NELLY

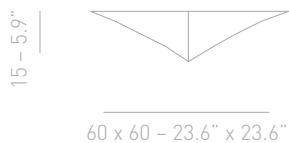

code **PL NEL Q 60**  
 watt 2 x max 100 w  
 bulbs/ilcos IAA/F   
 socket 2 x E27  
 marks

watt 1 x max 55 w  
 bulbs/ilcos FSC   
 socket 1 x 2GX13  
 marks

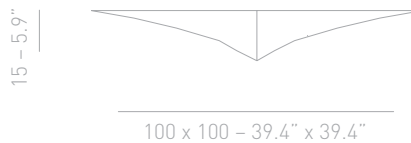

code **PL NE Q 100**  
 watt 3 x max 100 w  
 bulbs/ilcos IAA/F   
 socket 3 x E27  
 marks

watt 1 x max 55 w  
 bulbs/ilcos FSC   
 socket 1 x 2GX13  
 marks

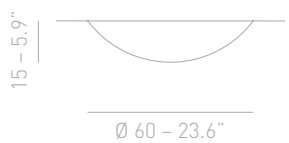

code **PL NELL 60**  
 watt 2 x max 100 w  
 bulbs/ilcos IAA/F   
 socket 2 x E27  
 marks

watt 1 x max 55 w  
 bulbs/ilcos FSC   
 socket 1 x 2GX13  
 marks

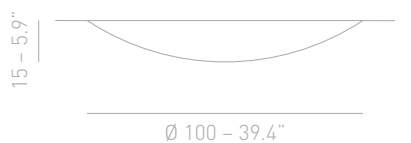

code **PL NEL 100**  
 watt 3 x max 100 w  
 bulbs/ilcos IAA/F   
 socket 3 x E27  
 marks

watt 1 x max 55 w  
 bulbs/ilcos FSC   
 socket 1 x 2GX13  
 marks

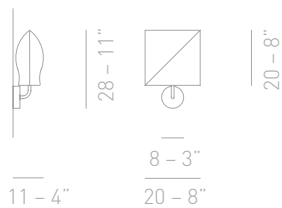

code **AP NELL BR**  
 watt 1 x max 60 w  
 bulbs/ilcos IBB/W   
 socket 1 x E14  
 marks

code **PT NELL 60**  
 watt 4 x max 100 w  
 bulbs/ilcos IAA/F   
 socket 4 x E27  
 marks

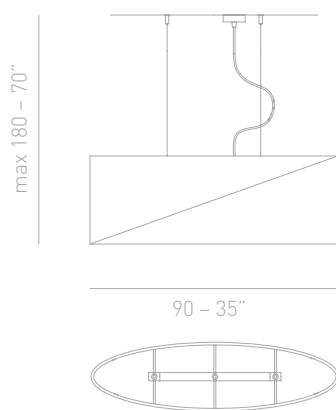

code **SP NELL 90**  
 watt 3 x max 100 w  
 bulbs/ilcos IAA/F   
 socket 3 x E27  
 marks

rosone - canopy  
 Ø 12 - 4.7"  
 H 6 - 2.4"

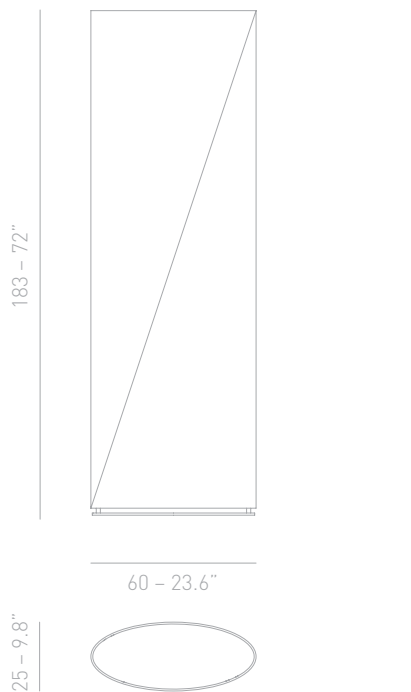

## NELLY

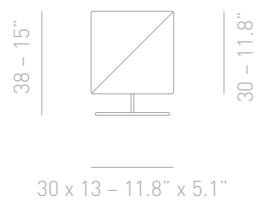

code **LT NELLY P**  
 watt 1 x max 60 w  
 bulbs/ilcos **IBB/W**   
 socket 1 x E14  
 marks **CE**

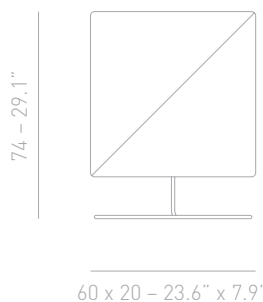

code **LT NELLY G**  
 watt 1 x max 100 w  
 bulbs/ilcos **IAA/F**   
 socket 1 x E27  
 marks **CE**

## PRIMULA

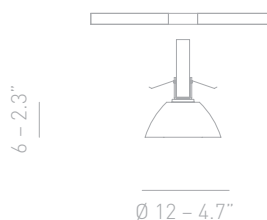

code **FA PRIMUL**  
 watt 1 x max 35 w  
 bulbs/ilcos **HSGST/UB**   
 socket 1 x GU 6.35  
 marks 12V **CE**

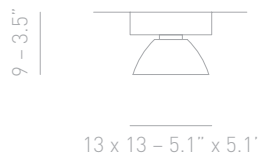

code **PL PRIMU 1**  
 watt 1 x max 35 w  
 bulbs/ilcos **HSGST/UB**   
 socket 1 x GY 6.35  
 marks 12V **CE**

foro - hole  
 Ø 4 - 1.6"  
 profondità min - min depth  
 10 - 3.9"

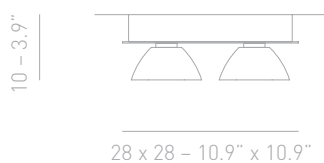

code **PL PRIMU 4**  
 watt 4 x max 35 w  
 bulbs/ilcos **HSGST/UB**   
 socket 4 x GY 6.35  
 marks 12V **CE**

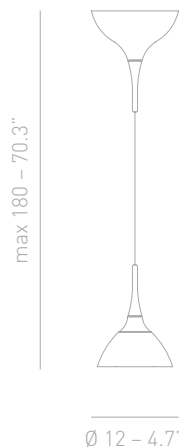

code **SP PRIM P 1**  
 watt 1 x max 35 w  
 bulbs/ilcos **HSGST/UB**   
 socket 1 x GY 6.35  
 marks 12V **CE**

rosone - canopy  
 Ø 12 - 4.7"  
 H 7.2 - 2.8"

## PRIMULA

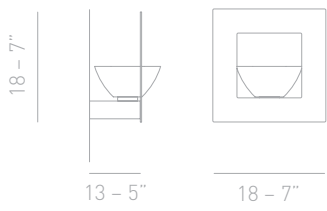



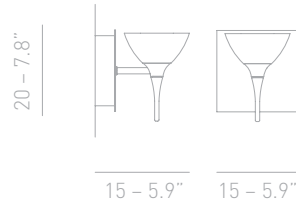

code **AP PRIMU 1**  
 watt 1 x max 35 w  
 bulbs/ilcos HSGST/UB   
 socket 1 x GY 6.35  
 marks 12V   



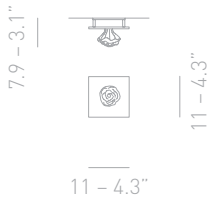



code **AP PRI 1 BR**  
 watt 1 x max 35 w  
 bulbs/ilcos HSGST/UB   
 socket 1 x GY 6.35  
 marks 12V   

## SHIRAZ

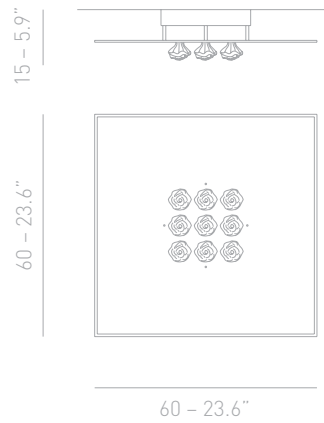

code **FA SHIRAZ**  
 watt 1 x max 35 w  
 bulbs/ilcos HAGS/UB   
 socket 1 x GU 5.3  
 marks 12V  





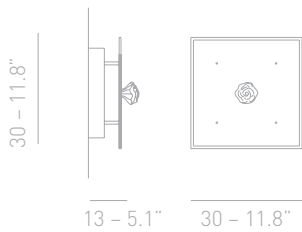

code **PL SHIRA G**  
 watt 1 x max 200 w  
 bulbs/ilcos HDG (118)   
 socket 1 x R7s  
 marks  

 foro - hole  
 Ø 6.5 - 2.6"  
 profondità min - min depth  
 10 - 3.9"

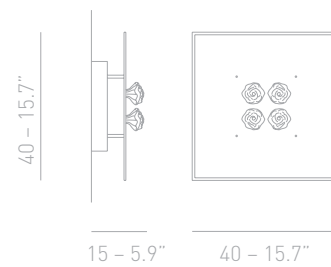

code **PL SHIRA P**  
 watt 1 x max 60 w  
 bulbs/ilcos HDG (78)   
 socket 1 x R7s  
 marks   



code **PL SHIRA M**  
 watt 1 x max 150 w  
 bulbs/ilcos HDG (118)   
 socket 1 x R7s  
 marks  

# SHIRAZ

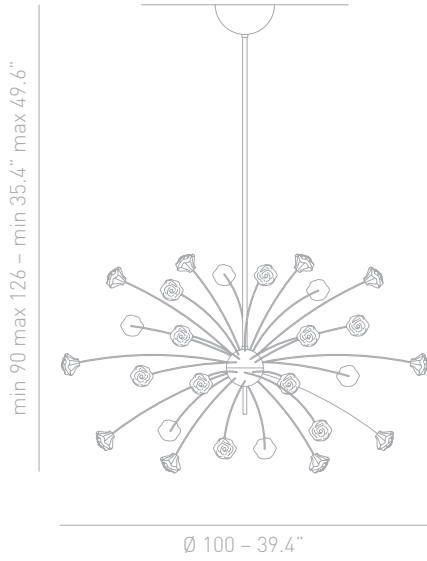

code **SP SHIR 18**  
 watt 18 x max 10 w  
 bulbs/ilcos HSGST/UB   
 socket 18 x G4  
 marks 12V

rosone - canopy  
 Ø 16 - 6.3"  
 H 8 - 3.1"



code **LT SHIRAZ**  
 watt 18 x max 10 w  
 bulbs/ilcos HSGST/UB   
 socket 18 x G4  
 marks 12V

# SLIGHT

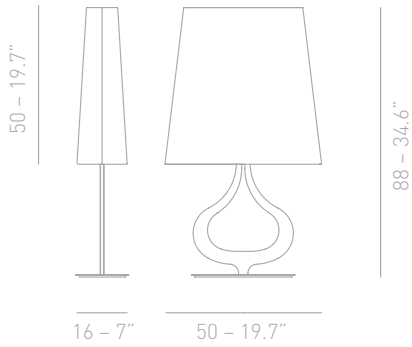

code **LT SLIGH G**  
 watt 1 x max 100 w  
 bulbs/ilcos IAA/F   
 socket 1 x E27  
 marks

watt 1 x max 20 w  
 bulbs/ilcos FBT   
 socket 1 x E27  
 marks

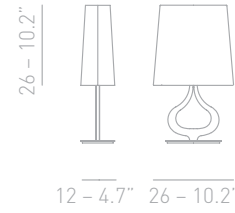

code **LT SLIGH P**  
 watt 1 x max 60 w  
 bulbs/ilcos IBB/W   
 socket 1 x E14  
 marks

watt 1 x max 11 w  
 bulbs/ilcos FBT   
 socket 1 x E14  
 marks

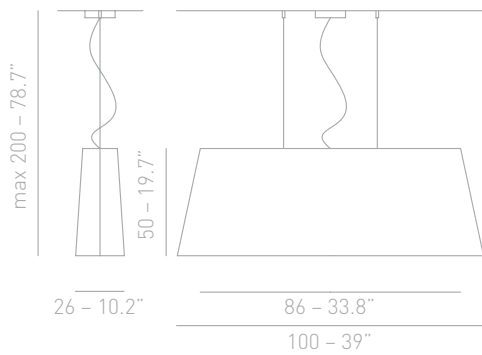

code **SP SLIGHT**  
 watt 2 x max 100 w  
 bulbs/ilcos IAA/F   
 socket 2 x E27  
 marks

watt 2 x max 20 w  
 bulbs/ilcos FBA   
 socket 2 x E27  
 marks

rosone - canopy  
 Ø 12 - 4.7"  
 H 2.5 - 1"

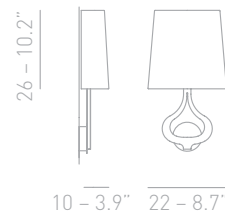

code **AP SLIGHT**  
 watt 1 x max 40 w  
 bulbs/ilcos IBB/W   
 socket 1 x E14  
 marks

watt 1 x max 9 w  
 bulbs/ilcos FBB   
 socket 1 x E14  
 marks

# SUBZERO

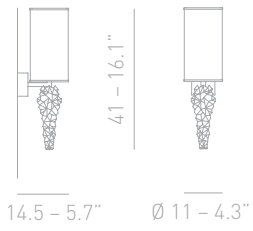

code **AP SUBZER**  
 watt 1 x max 40 w  
 bulbs/ilcos IBB/W   
 socket 1 x E14  
 marks

watt 1 x max 9 w  
 bulbs/ilcos FBB   
 socket 1 x E14  
 marks

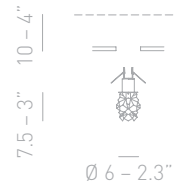

code **FA SUBZER**  
 watt 1 x max 20 w  
 bulbs/ilcos HSGST/UB   
 socket 1 x G4  
 marks 12V

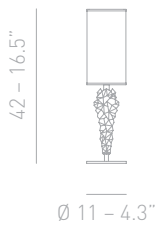

code **LT SUBZER**  
 watt 1 x max 40 w  
 bulbs/ilcos IBB/W   
 socket 1 x E14  
 marks

watt 1 x max 9 w  
 bulbs/ilcos FBB   
 socket 1 x E14  
 marks

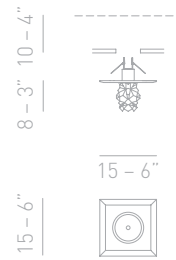

code **FA SUBZ 15**  
 watt 1 x max 20 w  
 bulbs/ilcos HSGST/UB   
 socket 1 x G4  
 marks 12V

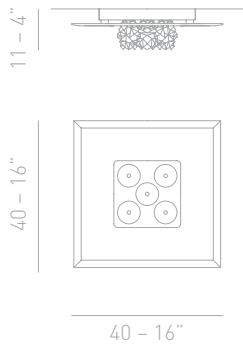

code **PL SUBZE 5**  
 watt 5 x max 20 w  
 bulbs/ilcos HSGST/UB   
 socket 5 x G4  
 marks 12V

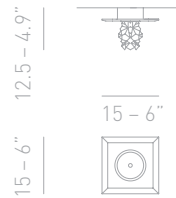

code **PL SUBZE 1**  
 watt 1 x max 20 w  
 bulbs/ilcos HSGST/UB   
 socket 1 x G4  
 marks 12V

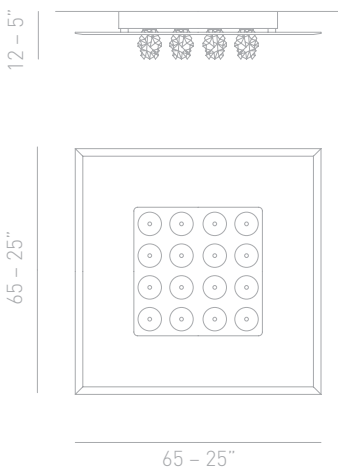

code **PL SUBZ 16**  
 watt 16 x max 20 w  
 bulbs/ilcos HSGST/UB   
 socket 16 x G4  
 marks 12V



code **SP SUBZE P**  
 watt 1 x max 20 w  
 bulbs/ilcos HSGST/UB   
 socket 1 x G4  
 marks 12V



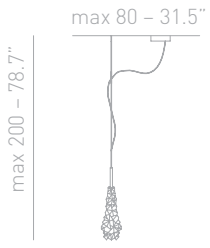

rosone - canopy  
 Ø 12-4.7"  
 H 4-1.6"

# SUBZERO







max 80 - 31.5"

Ø 6 - 2.3"

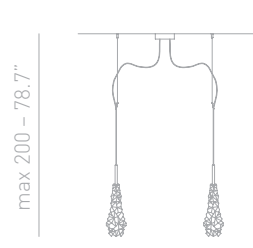
code **SP SUBZ DE**  
 watt 1 x max 20 w  
 bulbs/ilcos HSGST/UB   
 socket 1 x G4  
 marks 12V   

rosone - canopy  
 Ø 12 - 4.7"  
 H 4 - 1.6"



code **2x SP SUBZ DE**  
 watt 2 x max 20 w  
 bulbs/ilcos HSGST/UB   
 socket 2 x G4  
 marks 12V   



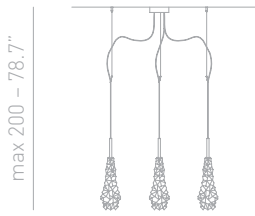

max 150 - 59"

rosone - canopy  
 Ø 14 - 5.5"  
 H 4 - 1.6"



max 200 - 78.7"

max 150 - 59"



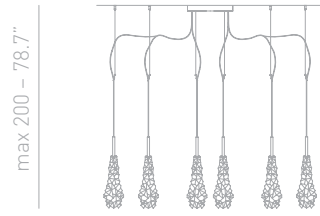

code **3x SP SUBZ DE**  
 watt 3 x max 20 w  
 bulbs/ilcos HSGST/UB   
 socket 3 x G4  
 marks 12V   

rosone - canopy  
 Ø 14 - 5.5"  
 H 4 - 1.6"



max 200 - 78.7"

max 200 - 78.7"

code **6x SP SUBZ DE**  
 watt 6 x max 20 w  
 bulbs/ilcos HSGST/UB   
 socket 6 x G4  
 marks 12V   

rosone - canopy  
 Ø 18 - 7.1"  
 H 5 - 2"

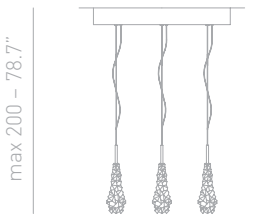





max 200 - 78.7"

6 - 2.3"



60 - 23"

code **SP SUBZE 3**  
 watt 3 x max 20 w  
 bulbs/ilcos HSGST/UB   
 socket 3 x G4  
 marks 12V   

rosone - canopy  
 60 x 4.5 x H 3.5  
 23.6" x 1.8" x H 1.4"

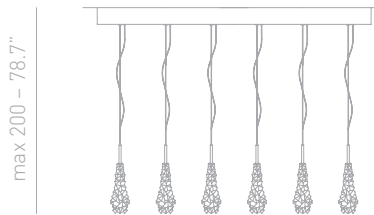





max 200 - 78.7"

6 - 2.3"



110 - 43"

code **SP SUBZE 6**  
 watt 6 x max 20 w  
 bulbs/ilcos HSGST/UB   
 socket 6 x G4  
 marks 12V   



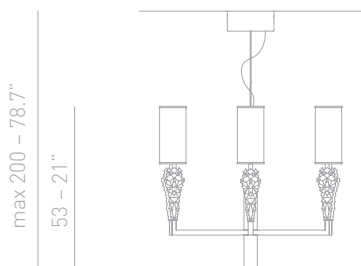

rosone - canopy  
 110 x 5.5 x H 6  
 43.3" x 2.2" x H 2.4"



max 200 - 78.7"

53 - 21"

Ø 65 - 25"

code **SP SUBZ 06**  
 watt 6 x max 40 w  
 + 1 x max 50 w  
 bulbs/ilcos IBB/W + HRGS/UB  
 +  alu  
 socket 6 x E14  
 + 1 x GU10  
 marks   

rosone - canopy  
 Ø 14 - 5.5"  
 H 6 - 2.4"

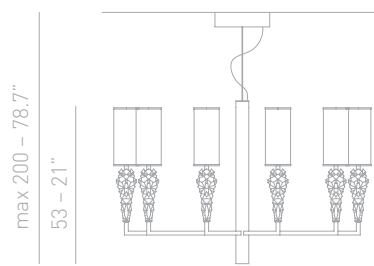

max 200 - 78.7"

53 - 21"

Ø 81 - 32"

code **SP SUBZ 10**  
 watt 10 x max 40 w  
 + 1 x max 50 w  
 bulbs/ilcos IBB/W + HRGS/UB  
 +  alu  
 socket 10 x E14  
 + 1 x GU10  
 marks   

rosone - canopy  
 Ø 14 - 5.5"  
 H 6 - 2.4"

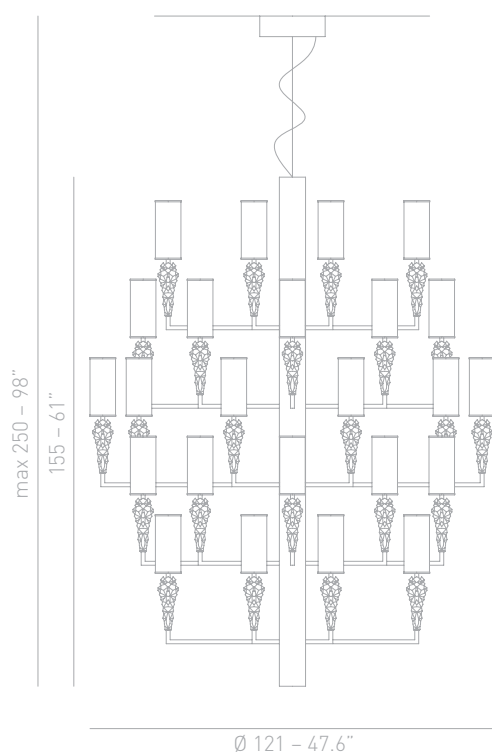

# SUBZERO

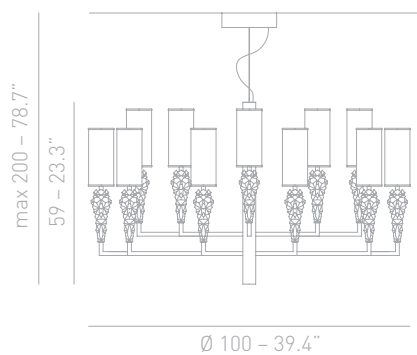

code **SP SUBZ 50**  
 watt 50 x max 40 w  
 + 1 x max 50 w  
 bulbs/ilcos IBB/W + HRGS/UB  
 ⚪ + 🔊 alu  
 socket 50 x E14  
 + 1 x GU10  
 marks **CE**  

rosone - canopy  
 Ø 14 - 5.5"  
 H 6 - 2.4"



code **SP SUBZ 20**  
 watt 20 x max 40 w  
 + 1 x max 50 w  
 bulbs/ilcos IBB/W + HRGS/UB  
 ⚪ + 🔊 alu  
 socket 20 x E14  
 + 1 x GU10  
 marks **CE**  

rosone - canopy  
 Ø 14 - 5.5"  
 H 6 - 2.4"

L'Ufficio Tecnico Axo Light è a disposizione per lo studio e lo sviluppo di progetti speciali.  
 Axo Light Technical Department is available to study and develop special projects.



## TECHNICAL DATA



Prodotto sottoposto alle prove di sicurezza elettrica e conforme alle Direttive Comunitarie Europee EN60598-1

Product undergone to electric safety tests, conform to ECC Directive EN60598-1

Producto sometido a las pruebas de seguridad eléctrica y conforme con las directivas comunitarias europeas EN60598-1

Produkt entsprechend dereuropäischen Norm EN60598-1

Produit soumis aux tests de sécurité, conforme aux Directives CEE EN60598-1

Изделие подвержено электрическому испытанию. Оно соответствует указаниям Европейского Общества EN60598-1.



Apparecchi predisposti per il montaggio direttamente su superfici infiammabili

Fixtures prepared for the mounting on flammable surfaces

Aparatos predisuestos para el montaje directamente sobre superficies inflamables

Geräte für Montage auf entflammbare Oberflächen geeignet sind

Appareils prévus pour le montage sur surfaces inflammables

Изделия могут быть установлены на воспламеняющейся поверхности.



Solo isolamento fondamentale; le parti conduttrici accessibili sono collegate ad un conduttore di terra. Messa a terra obbligatoria

Basic insulation, accessible conductors are earthed. Earthing is obligatory

Solo aislamiento fundamental; las partes conductoras accesibles están conectadas a un conductor de tierra. Puesta a tierra obligatoria.

Grundisolation: berührbare Metallteile mit Anschlussstelle für Schutzleiter verbunden. Netzschutzleiter: vorgeschrieben.

Isolation de base: les parties conductrices accessibles sont mises à terre. Mise à terre obligatoire

Изоляция только базовая. Доступные проводниковые части подсоединены к заземлителю. Заземление обязательно.



Sistema a doppio isolamento; messa a terra esclusa.

Double insulation. Earthing: excluded.

Sistema de doble aislamiento; puesta a tierra no incluida.

Doppelte Isolierung. Netzschutzleiter: nicht erlaubt.

Double isolation. Mise à la terre: exclue.

Система двойной изоляции. Заземление необязательно.



Apparecchio in cui la protezione contro la scossa elettrica si basa sulla alimentazione a bassissima tensione di sicurezza.

Appliance in which protection against electrical shock is guaranteed by the extremely low-voltage power supply.

Aparado en el qual la proteccion contra la descarga eléctrica se debe a la alimentación a muy baja tensión.

Zum Schutz vor elektrischen Schlägen mit Kleinspannung Gespeistes Gerät.

Appareil avec protection contre les décharges électriques basée sur l'alimentation à une tension de sécurité très basse.

Прибор, в котором защита от удара током основана на питании от очень низкого напряжения.

## ADA



Prodotto conforme alla normativa USA A.D.A. (protruding objects).

Product conforms to the USA A.D.A. standards (protruding objects).

Producto conforme con la normativa USA A.D.A. (protruding objects).

Produkt gemäß USA-Regelung A.D.A. (protruding objects).

Produit conforme à la norme USA A.D.A. (protruding objects).

Изделие соответствует нормативам США A.D.A. (protruding objects).

Predisposto con variatore di luce.

With dimmer.

Mit Dimmer.

Avec dimmer.

Con dimmer.

Предусмотрено с диммер.

Axo Light si riserva il diritto di apportare ai modelli, senza alcun preavviso, qualsiasi modifica ritenesse opportuna. Axo Light non risponde per eventuali danni a persone o cose causati da una non corretta installazione dei propri apparecchi d'illuminazione.

Axo Light reserves itself the right to introduce any changes to its own models, without prior notice. Axo Light is not liable for injuries or damage due to the incorrect installation of its fixtures.

Axo Light se reserva el derecho de aportar a los propios modelos, sin ningún preaviso, cualquier modificación que se considere oportuna. Axo Light no responde por los eventuales daños causados a personas o cosas provocados por una incorrecta instalación de los propios aparatos de iluminación.

Axo Light behält sich das Recht vor, jederzeit und ohne Voranmeldung, Änderungen der Kollektion vorzunehmen, ohne jedoch die charakteristischen Eigenschaften der Artikel zu ändern. Axo Light ist nicht verantwortlich für eventuelle Personen -oder Sachschäden, verursacht durch unsachgemäße Installation der Produkte.

Axo Light se réserve le droit de modifier ses collections à tous moments et sans préavis, dans le respect des caractéristiques de base du produit. Axo Light ne répond pas aux éventuels dommages à personnes ou choses causés par une mauvaise installation de ses appareils d'éclairage.

Axo Light оставляет за собой право вносить модификации моделей без предупреждения, в случае необходимости. Axo Light не несёт ответственности за ущерб людям или вещам, вызванный некорректной установкой осветительных приборов.







**Axo Light srl**

via Moglianese 40  
30037 Scorzé  
Venezia, Italy  
t +39 041 5845193  
f +39 041 5845060  
www.axolight.it  
axolight@axolight.it